

CODE OF PRACTICE THREE

**CODE OF PRACTICE FOR THE METERING OF CIRCUITS
WITH A RATED CAPACITY NOT EXCEEDING 10MVA
FOR SETTLEMENT PURPOSES.**

Issue 5

Version 6.0

Date: 6 November 2008

Code of Practice Three

CODE OF PRACTICE FOR THE METERING OF CIRCUITS WITH A RATED CAPACITY NOT EXCEEDING 10MVA FOR SETTLEMENT PURPOSES.

1. Reference is made to the Balancing and Settlement Code for the Electricity Industry in Great Britain, and, in particular, to the definition of "Code of Practice" in Annex X-1 thereof.
2. This Code of Practice shall apply to Metering Systems comprising Metering Equipment that are subject to the requirements of Section L of the Balancing and Settlement Code.
3. This Code of Practice has been approved by the Panel.

SUPERSEDED

Intellectual Property Rights, Copyright and Disclaimer

The copyright and other intellectual property rights in this document are vested in ELEXON or appear with the consent of the copyright owner. These materials are made available for you for the purposes of your participation in the electricity industry. If you have an interest in the electricity industry, you may view, download, copy, distribute, modify, transmit, publish, sell or create derivative works (in whatever format) from this document or in other cases use for personal academic or other non-commercial purposes. All copyright and other proprietary notices contained in the document must be retained on any copy you make.

All other rights of the copyright owner not expressly dealt with above are reserved.

No representation, warranty or guarantee is made that the information in this document is accurate or complete. While care is taken in the collection and provision of this information, ELEXON Limited shall not be liable for any errors, omissions, misstatements or mistakes in any information or damages resulting from the use of this information or action taken in reliance on it.

AMENDMENT RECORD

ISSUE	DATE	VERSION	CHANGES	AUTHOR	APPROVED
Draft	18/3/93	0.03	Recommended to PEC	MSC	
1	15/4/93	1.00	Endorsed by PEC	COP WG	
	19/4/95	1.01	Draft	COPWG	
	14/6/95	1.02	Draft	COPWG	
	22/6/95	1.03	Draft for MDC	COP WG	
	27/7/95	1.04	Draft following comments by MDC	COP WG	Approved by MDC 7/9/95
2	8/9/95	2.00	Implementation date agreed by MDC	COP WG	
3	1/5/97	2.03	Amendments for 100kW Take-on	1998 Programme	Approved by MDC 1/5/97
	1/9/97	2.05	Amended following review by Expert Group and internally.	1998 Programme (CA Team)	
	25/3/98	2.06	Draft for MDC	CoPSRP	
	20/4/98	2.07	Post MDC revisions and CoPSRP on 17/4/98	CoPSRP	
4	1998 Operational Date	2.05	Amended following review by Expert Group and internally.	1998 Programme (CA Team)	
5	1/9/98	3.00	Harmonisation of Codes of Practice	COPSRP	Approved by MDC 4/6/98
5	Code Effective Date ¹	3.00	Re-badging of Code of Practice Three for the implementation of the Balancing and Settlement Code	BSCCo	Panel 16/11/00 (Paper 07/003)
5	BETTA Effective Date	4.0	BETTA 6.3 and CP 794 for the SVA February 2005 Release	BSCCo	SVG/48/004
5	03/11/05	5.0	CP1100 for the SVA November 2005 Release	BSCCo	SVG/56/004
5	06/11/08	6.0	CP1238 for November 08 Release	BSCCo	ISG88/01 SVG88/02

¹ "Code Effective Date" means the date of the Framework Agreement.

CODE OF PRACTICE FOR THE METERING OF CIRCUITS WITH A RATED CAPACITY NOT EXCEEDING 10MVA FOR SETTLEMENT PURPOSES.

1.	SCOPE.....	7
2.	REFERENCES	8
3.	DEFINITIONS AND INTERPRETATIONS.....	9
3.1	ACTIVE ENERGY *.....	9
3.2	ACTIVE POWER *.....	9
3.3	ACTUAL METERING POINT ‡.....	9
3.4	APPARENT ENERGY ‡.....	9
3.5	APPARENT POWER ‡.....	9
3.6	CTN ‡.....	9
3.7	CVA CUSTOMER †.....	9
3.8	DE-ENERGISED ‡.....	9
3.9	DEFINED METERING POINT ‡.....	10
3.10	DEMAND PERIOD ‡.....	10
3.11	DEMAND VALUES ‡.....	10
3.12	ELECTRICITY *.....	10
3.13	EXPORT †.....	10
3.14	IMPORT †.....	10
3.15	INTERROGATION UNIT ‡.....	10
3.16	MAXIMUM DEMAND †.....	10
3.17	METER *.....	10
3.18	METERING EQUIPMENT *.....	11
3.19	METER REGISTER ‡.....	11
3.20	METERING SYSTEM *.....	11
3.21	OUTSTATION *.....	11
3.22	OUTSTATION SYSTEM ‡.....	11
3.23	PASSWORD ‡.....	11
3.24	PSTN ‡.....	11
3.25	RATED MEASURING CURRENT ‡.....	11
3.26	REACTIVE ENERGY *.....	11
3.27	REACTIVE POWER *.....	12
3.28	REGISTRANT.....	12
3.29	SETTLEMENT INSTANTION ‡.....	12
3.30	SVA CUSTOMER.....	12
3.31	UTC ‡.....	12
4.	MEASUREMENT CRITERIA	13
4.1	MEASURED QUANTITIES AND DEMAND VALUES.....	13
4.1.1	<i>Measured Quantities</i>	13
4.1.2	<i>Demand Values</i>	13
4.2	ACCURACY REQUIREMENTS.....	14
4.2.1	<i>Overall Accuracy</i>	14
4.2.2	<i>Compensation for Measurement Transformer Error</i>	15
4.2.3	<i>Compensation for Power Transformer and Line Losses</i>	15
5.	METERING EQUIPMENT CRITERIA	16
5.1	MEASUREMENT TRANSFORMERS	16
5.1.1	<i>Current Transformers</i>	16
5.1.2	<i>Voltage Transformers</i>	16
5.1.3	<i>Measurement Transformers Installed on Existing Circuits</i>	17
5.2	FUSING AND TESTING FACILITIES.....	17
5.3	METERS.....	18
5.4	DISPLAYS AND FACILITIES FOR REGISTRANT OR SUPPLIER INFORMATION.....	18
5.4.1	<i>Displays</i>	18
5.4.2	<i>Facilities</i>	19
5.5	OUTSTATION.....	19

5.5.1	<i>Data Storage</i>	20
5.5.2	<i>Time Keeping</i>	21
5.5.3	<i>Monitoring Facilities</i>	21
5.6	COMMUNICATIONS	21
5.6.1	<i>Local Interrogation</i>	23
5.6.2	<i>Remote Interrogation</i>	23
5.7	APPROPRIATE SEALS	23
6.	ASSOCIATED FACILITIES	24
6.1	INTERROGATION UNIT	24
6.2	ADDITIONAL FEATURES	24
7.	ACCESS TO DATA	25
APPENDIX A	DEFINED METERING POINTS	26
APPENDIX A (CONT'D)	27
APPENDIX B	LABELLING OF METERS FOR IMPORT AND EXPORT	28
GENERATING PLANT	29
(CVA)	29
THIRD PARTY GENERATING PLANT	29
(SVA)	29
EXTERNAL SYSTEM (DIST. OR TRANS.)	29
CVA CUSTOMER	29
SVA CUSTOMER	29
EXPORT	29
APPENDIX C	TYPICAL TESTING FACILITIES AND FUSING ARRANGEMENTS	31
APPENDIX D	PASSWORDS	32
APPENDIX E	OPTIONS FOR ENSURING METERS AND DISPLAYS CAN BE READ AND REMOTELY INTERROGATED	33

FOREWORD

This Code of Practice defines the minimum requirements for the Metering Equipment required for the measurement and recording of electricity transfers at Defined Metering Points where the rated circuit capacity does not exceed 10MVA.

For the purpose of this Code of Practice the rated circuit capacity in MVA shall be determined by the lowest rated primary plant (e.g. transformer rating, line rating, etc) of the circuit. The Metering Equipment provision and accuracy requirements shall anticipate any future up-rating consistent with the installed primary plant. The primary plant maximum continuous ratings shall be used in this assessment.

BSCCo shall retain copies of, inter alia, the Code of Practice together with copies of all documents referred to in them, in accordance with the provisions of the Balancing and Settlement Code (the Code).

SUPERSEDED

1. SCOPE

This Code of Practice states the practices that shall be employed, and the facilities that shall be provided for the measurement and recording of the quantities required for Settlement purposes on each circuit where the rated capacity does not exceed 10MVA.

It derives force from the Code, and in particular the metering provisions (Section L), to which reference should be made. It should also be read in conjunction with the BSC Procedures.

This Code of Practice does not contain the calibration, testing and commissioning requirements for Metering Equipment used for Settlement purposes. These requirements are detailed in Code of Practice Four - "Code of Practice for Calibration, Testing and Commissioning Requirements for Metering Equipment for Settlement Purposes".

Metering Dispensations from the requirements of this Code of Practice may be sought in accordance with the Code and BSCP32.

Meters and Outstations referred to in this Code of Practice shall only achieve successful compliance in respect of any testing detailed in this Code of Practice if the requirements set out in accordance with BSCP601 are also observed and successfully completed or the Registrant has been granted a valid Metering Dispensation covering any departure from the requirements as detailed in this Code of Practice.

Generic Metering Dispensations applicable to this Code of Practice are located on the BSCCo website (www.elexon.co.uk).

In the event of an inconsistency between the provisions of this Code of Practice and the Code, the provisions of the Code shall prevail.

2. REFERENCES

The following documents are referred to in the text:-

BS EN 61036	AC Static Watthour Meters for Active Energy (Classes 1 and 2)
BS EN 60521	Specification for Class 0.5, 1 and 2 Single-Phase and Polyphase, Single Rate and Multi-Rate Watt-Hour Meters
BS EN 61268	Alternating Current Static Var-Hour Meters for Reactive Energy (Classes 2 and 3)
BS 5685 Part 4	Specification for Class 3 Var-Hour Meters
IEC Standard 44-3	Instrument Transformers - Combined Transformers
IEC Standard 185	Current Transformers
IEC Standard 186	Voltage Transformers
BS EN 61107	Data Exchange for Meter Reading, Tariff and Load Control. Direct Local Exchange.
Balancing and Settlement Code	Section X; Annex X-1 and Section L and BSC Procedures
Code of Practice Four	Code of Practice for Calibration, Testing and Commissioning Requirements for Metering Equipment for Settlement Purposes
BSC Procedures	See BSC Procedures
Electricity Act 1989	Schedule 7 as amended by Schedule 1 to the Competition and Services (Utilities) Act 1992.
Meter Operator Code of Practice Agreement	Agreement between Meter Operators and Distribution Businesses governing arrangements for safety and technical competence.
Standard Frequency and Time Signal Emission	International Telecommunication Union - RTF.460(ISBN92-61-05311-4)

3. DEFINITIONS AND INTERPRETATIONS

Save as otherwise expressly provided herein, words and expressions used in this Code of Practice shall have the meanings attributed to them in the Code and are included for the purpose of clarification.

Note: * indicates definitions in the Code.

Note: † indicates definitions which supplement or complement those in the Code.

Note: ‡ indicates definitions specific to this Code of Practice.

3.1 Active Energy *

Active Energy means the electrical energy produced, flowing or supplied by an electric circuit during a time interval, being the integral with respect to time of the instantaneous Active Power, measured in units of watt-hours or standard multiples thereof;

3.2 Active Power *

Active Power means the product of voltage and the in-phase component of alternating current measured in units of watts and standard multiples thereof, that is:

$$1,000 \text{ Watts} = 1 \text{ kW}$$

$$1,000 \text{ kW} = 1 \text{ MW}$$

3.3 Actual Metering Point ‡

Actual Metering Point means the physical location at which electricity is metered.

3.4 Apparent Energy ‡

Apparent Energy means the integral with respect to time of the Apparent Power.

3.5 Apparent Power ‡

Apparent Power means the product of voltage and current measured in units of volt-amperes and standard multiples thereof, that is:-

$$1,000 \text{ VA} = 1 \text{ kVA}$$

$$1,000 \text{ kVA} = 1 \text{ MVA}$$

3.6 CTN ‡

CTN means the Electricity Supply Industry (ESI) corporate telephone network.

3.7 CVA Customer †

CVA Customer means any customer, receiving electricity directly from the Transmission System, irrespective of from whom it is supplied.

3.8 De-Energised ‡

De-Energised means the temporary removal of the supply at a Defined Metering Point (e.g. the main circuit connections to the Public Distribution System Operators network

are still made) such that all or part of the Metering Equipment is considered to be temporarily "inactive" for the purposes of Settlement. e.g. unoccupied premises where the incoming switchgear has been opened or the cut-out fuse(s) removed.

3.9 Defined Metering Point ‡

Defined Metering Point means the physical location at which the overall accuracy requirements as stated in this Code of Practice are to be met. The Defined Metering Points are identified in Appendix A and relate to Boundary Points and System Connection Points.

3.10 Demand Period ‡

Demand Period means the period over which Active Energy, Reactive Energy or Apparent Energy are integrated to produce stored energy values. For Settlement purposes, unless the context requires otherwise, each Demand Period shall be of 30 minutes duration, one of which shall finish at 24:00 hours.

3.11 Demand Values ‡

Demand Values means, expressed in kW, kvar or kVA, twice the value of kWh, kvarh or kVAh recorded during any Demand Period. The Demand Values are half hour demands and these are identified by the time of the end of the Demand Period.

3.12 Electricity *

electricity means Active Energy and Reactive Energy.

3.13 Export †

Export means, for the purposes of this Code of Practice, an electricity flow as indicated in Figure 1 of Appendix B.

3.14 Import †

Import means, for the purposes of this Code of Practice, an electricity flow as indicated in Figure 1 of Appendix B.

3.15 Interrogation Unit ‡

Interrogation Unit means a Hand Held Unit "HHU" (also known as Local Interrogation Unit LIU") or portable computer which can enter Metering Equipment parameters and extract information from the Metering Equipment and store this for later retrieval.

3.16 Maximum Demand †

Maximum Demand expressed in kW or kVA means twice the greatest number of kWh or kVAh recorded during any Demand Period.

3.17 Meter *

Meter means a device for measuring Active Energy and/or Reactive Energy.

3.18 Metering Equipment *

Metering Equipment means Meters, measurement transformers (voltage, current or combination units), metering protection equipment including alarms, circuitry, associated Communications Equipment and Outstation and wiring.

3.19 Meter Register ‡

Meter Register means a device, normally associated with a Meter, from which it is possible to obtain a reading of the amount of Active Energy, or the amount of Reactive Energy that has been supplied by a circuit.

3.20 Metering System *

Metering System means particular commissioned Metering Equipment, as defined in Section X; Annex X-1 of the Balancing and Settlement Code.

3.21 Outstation *

Outstation means equipment which receives and stores data from a Meter(s) for the purpose, *inter-alia*, of transfer of that metering data to the Central Data Collector Agent (CDCA) or Data Collector as the case may be, and which may perform some processing before such transfer and may be in one or more separate units or may be integral with the Meter.

3.22 Outstation System ‡

Outstation System means one or more Outstations linked to a single communication line.

3.23 Password ‡

Password means a string of characters of length no less than six characters and no more than twelve characters, where each character is a case insensitive alpha character (A to Z) or a digit (0 to 9) or the underscore character (_). Passwords must have a minimum of 2,000,000,000 combinations, for example six characters if composed of any alphanumeric characters or eight characters if composed only of hexadecimal characters (0 to F).

3.24 PSTN ‡

PSTN means the public switched telephone network.

3.25 Rated Measuring Current ‡

Rated Measuring Current means the rated primary current of the current transformers in primary plant used for the purposes of measurement.

3.26 Reactive Energy *

Reactive Energy means the integral with respect to time of the Reactive Power.

3.27 Reactive Power *

Reactive Power means the product of voltage and current and the sine of the phase angle between them, measured in units of voltamperes reactive and standard multiples thereof.

3.28 Registrant

Registrant means in relation to a Metering System, the person for the time being registered in CMRS or (as the case may be) SMRS in respect of that Metering System pursuant to Section K of the Balancing and Settlement Code.

3.29 Settlement Instation ‡

Settlement Instation means a computer based system which collects or receives data on a routine basis from selected Outstation by the Central Data Collector or (as the case may be) a relevant Data Collector.

3.30 SVA Customer

means a person to whom electrical power is provided, whether or not that person is the provider of that electrical power; and where that electrical power is measured by a SVA Metering System.

3.31 UTC ‡

UTC means Co-ordinated Universal Time which bears the same meaning as in the document Standard Frequency and Time Signal Emission, International Telecommunication Union - RTF.460(ISBN92-61-05311-4) (colloquially referred to as Rugby Time).

4. MEASUREMENT CRITERIA

4.1 Measured Quantities and Demand Values

4.1.1 Measured Quantities

For each separate circuit the following energy measurements are required for Settlement purposes:-

- (i) Import kWh
- (ii) Export kWh }*
- (iii) Import kvarh
- (iv) Export kvarh

4.1.2 Demand Values

For each Demand Period for each circuit the following Demand Values shall be provided:-

- (i) Import kW
- (ii) Export kW }*
- (iii) Import kvar
- (iv) Export kvar

* Import and/or Export metering need only be installed where a Party requires this measurement to meet system or plant conditions.

Where Import and Export metering is installed gross Import and gross Export Active Energy shall be recorded separately for Settlements.

For multiple circuit connections between Parties the configuration of the Metering Equipment shall be agreed in advance with the Panel.

4.2 Accuracy Requirements

4.2.1 Overall Accuracy

The overall accuracy of the energy measurements at or referred to the Defined Metering Point shall at all times be within the limits of error as shown:-

(i) Active Energy

CONDITION	LIMIT OF ERRORS AT STATED SYSTEM POWER FACTOR	
	Power Factor	Limits of Error
Current expressed as a percentage of Rated Measuring Current		
120% to 10% inclusive	1	± 1.5%
Below 10% to 5%	1	± 2.0%
120% to 10% inclusive	0.5 lag and 0.8 lead	± 2.5%

(ii) Reactive Energy

CONDITION	LIMIT OF ERRORS AT STATED SYSTEM POWER FACTOR	
	Power Factor	Limits of Error
Current expressed as a percentage of Rated Measuring Current		
120% to 10% inclusive	Zero	± 4.0%
120% to 20% inclusive	0.866 lag and 0.866 lead	± 5.0%

These limits of error for both (i) and (ii) above shall apply at the Reference Conditions defined in the appropriate Meter specification.

Evidence to verify that these overall accuracy requirements are met shall be available for inspection by either the Panel or the Technical Assurance Agent.

4.2.2 Compensation for Measurement Transformer Error

To achieve the overall accuracy requirements it may be necessary to compensate Meters for the errors of the measurement transformers and the associated leads to the Meters. Values of the compensation shall be recorded and evidence to justify the compensation criteria, including wherever possible test certificates, shall be available for inspection by either the Panel or the Technical Assurance Agent. Where CT test certificates are not available and the CTs can be verified as class 0.5 or better and are installed on an LV installation, the extreme errors for the accuracy class shall be assumed.

4.2.3 Compensation for Power Transformer and Line Losses

Where the Actual Metering Point and the Defined Metering Point do not coincide a Metering Dispensation shall be applied for and, where necessary, compensation for power transformer and/or line losses shall be provided to meet the overall accuracy at the Defined Metering Point.

The compensation may be achieved in the Metering Equipment and in this event the applied values shall be recorded. Supporting evidence to justify the compensation criteria shall be available for inspection by either the Panel or the Technical Assurance Agent.

Alternatively, the compensation may be applied in the software of the relevant data aggregation system used for Settlement purposes. In this event the factors shall be passed to the appropriate agency and evidence to justify the compensation criteria shall be made available for inspection by either the Panel or the Technical Assurance Agent.

5. METERING EQUIPMENT CRITERIA

Although for clarity this Code of Practice identifies separate items of equipment, nothing in it prevents such items being combined to perform the same task provided the requirements of this Code of Practice are met.

Metering Equipment other than outdoor measurement transformers, shall be accommodated in a clean and dry environment.

For each circuit, other than one which is permanently disconnected, the voltage supply to any Meters, Displays and Outstations shall be connected such that it is normally energised to facilitate reading of the Meter Register(s) and Local and Remote Interrogation of the Outstation. (see Appendix E).

Where an Outstation is storing data for more than one circuit and the Outstation power supply is from these circuits then a voltage selection relay scheme using each circuit involved shall be provided.

5.1 Measurement Transformers

The terms "current transformer" and "voltage transformer" used below in 5.1.1 and 5.1.2 do not preclude the use of other measuring techniques with a performance equal to that specified for such measurement transformers.

For each circuit current transformers (CT) and voltage transformers (VT) shall meet the requirements set out in clauses 5.1.1 and 5.1.2.

Additionally, where a combined unit measurement transformer (VT & CT) is provided the 'Tests for Accuracy' as covered in clause 8 of IEC Standard 44-3 covering mutual influence effects shall be met.

5.1.1 Current Transformers

One set of current transformers in accordance with IEC Standard 185 and with a minimum standard of accuracy to Class 0.5 shall be provided per circuit. Preferably the current transformers shall be dedicated for Settlement purposes, but the CTs may be used for other purposes provided the overall accuracy requirements in clause 4.2.1 are met and evidence of the value of the additional burden is available for inspection by either the Panel or the Technical Assurance Agent.

The additional burden shall not be modified without prior notification to the Panel, and evidence of the value of the modified additional burden shall be available for inspection by either the Panel or the Technical Assurance Agent.

CT test certificates showing errors at the overall working burden or at burdens which enable the working burden errors to be calculated shall be available for inspection by either the Panel or the Technical Assurance Agent.

The total burden on each current transformer shall not exceed the rated burden of such CT.

5.1.2 Voltage Transformers

A single voltage transformer secondary winding in accordance with IEC Standard 186 and with a minimum standard of accuracy to Class 1 shall be provided for the main and check metering of a circuit. The voltage transformer secondary winding may be used for other purposes provided the overall accuracy requirements in clause 4.2.1 are

met and evidence of the value of the additional burden is available for inspection by either the Panel or the Technical Assurance Agent.

The additional burden shall not be modified without prior notification to the Panel, and evidence of the value of the modified additional burden shall be available for inspection by either the Panel or the Technical Assurance Agent.

A VT test certificate(s) showing errors at the overall working burden(s) or at burdens which enable the working burden errors to be calculated shall be available for inspection by either the Panel or the Technical Assurance Agent.

The total burden on each secondary winding of a VT shall not exceed the rated burden of such secondary winding.

The VT supplies shall be fused as close as practicable to the VT, with a set of isolating links, suitably identified, provided locally to the Metering Equipment.

5.1.3 Measurement Transformers Installed on Existing Circuits

Where circuits, other than those newly installed, are to be metered to this Code of Practice and where the installed measurement transformers do not comply with the class accuracies specified in clauses 5.1.1 & 5.1.2, then such measurement transformers may be used providing the following requirements and those in clause 4.2.1 are met:-

- (i) Where subsequently a significant alteration to the primary plant (e.g. a switchgear change) is carried out, new measurement transformers as detailed in clauses 5.1.1 and 5.1.2, shall be provided.
- (ii) In all other respects the requirements of clauses 5.1.1 and 5.1.2 are met, except that where test certificates are not available other documentary evidence as referred to in clause 4.2.2 shall be available.

5.2 Fusing and Testing Facilities

Testing facilities shall be provided close by the Meters of each circuit, which enables such Meters to be routinely tested and/or changed safely with the circuit energised. (see Appendix C)

Separate fusing shall be provided locally for:-

- (i) the main Meter
- (ii) the check Meter
- (iii) any other Settlement Metering Equipment burden
- (iv) any other Equipment burden e.g. non-Pool Meters, protection, etc.

Local fusing shall discriminate with the source fusing.

A typical arrangement is illustrated in Appendix C.

Where Current Transformers are used on low voltage installations, the voltage supply to the Metering Equipment shall be fused as close as practicable to the point of that supply with a set of isolating links, suitably identified, provided locally to the Metering Equipment. If that point of supply is close to the Metering Equipment, then the isolating links may be omitted.

5.3 Meters

The Meters may be either static or induction disc types.

For each circuit main and check Active Energy Meters shall be supplied. These Meters shall meet the requirements of either BS EN 61036 Class 1 or BS EN 60521 Class 1.

Active Energy Meters provided for the metering of supplies to customers shall be in accordance with Schedule 7 of the Electricity Act 1989.

For each circuit, only main Reactive Energy Meter(s) need be supplied. The Reactive Energy Meters shall meet the requirements of either BS EN 61268 Class 3 or BS 5685 Part 4.

Active Energy Meters shall be configured such that the number of measuring elements is equal to or one less than the number of primary system conductors. These include the neutral conductor, and/or the earth conductor where system configurations enable the flow of zero sequence energy.

All Meters supplied via measurement transformers shall be set to the actual primary and secondary ratings of the measurement transformers and the ratios displayed as follows:-

- (i) For Meters separate from the display and/or Outstation the ratios shall be recorded on the nameplate of the Meter.
- (ii) For static Meters combined with the display and/or the Outstation, the ratios shall be displayed and downloaded during the interrogation process. In addition, the compensation factor that has been applied for measurement transformer errors and/or system losses, where this is a constant factor applied at security level 3 shall be similarly displayed and downloaded.

All Meters shall include a non-volatile Meter Register of cumulative energy for each measured quantity (see 4.1.1). The Meter Register(s) shall not roll-over more than once within the normal Meter reading cycle.

Meters which provide data to separate Outstations shall for this purpose provide an output per measured quantity (see 4.1.1).

For Meters using electronic displays due account shall be taken of the obligations of the Central Data Collector Agent (CDCA) or other Data Collectors to obtain Meter readings, even when the circuit is de-energised.

All Meters shall be labelled or otherwise be readily identifiable with respect to their associated circuit(s), and in accordance with Appendix B.

5.4 Displays and Facilities for Registrant or Supplier Information

5.4.1 Displays

a) Mandatory Displays

The Metering Equipment shall display the following primary information (not necessarily simultaneously):-

- (i) measured quantities as per clause 4.1.1;
- (ii) current time ("UTC") and date;

- (iii) the CT and/or VT ratios that the Meter has been programmed to, where appropriate (see clause 5.3); and
- (iv) the compensation factor that has been applied for measurement transformer errors and/or system losses, where this is a constant factor applied at security level 3 (i.e. where the Meter is combined with the display and/or Outstation).

b) Display Capabilities

The Metering Equipment shall be capable of enabling the display of the following information, as specified by the Registrant:-

- (i) Maximum Demand ("MD") for kW per programmable charging period, i.e. monthly or statistical review period;
- (ii) Maximum Demand ("MD") for kVA per programmable charging period, i.e. monthly or statistical review period;
- (iii) twice the kWh advance since the commencement of a current Demand Period, (i.e. "kW rising demand");
- (iv) twice the kVAh advance since the commencement of a current Demand Period, (i.e. "kVA rising demand");
- (v) cumulative MD;
- (vi) number of MD resets;
- (vii) multi-rate display sequence as specified by the Registrant, with a minimum of 8 rates selectable over the calendar year; and
- (viii) indication of reverse running for Active Energy, where appropriate.

MD shall be resettable at midnight of the last day of a charging period and for part chargeable period demands. If a manual reset button is provided then this shall be sealable.

5.4.2 Facilities

The Metering Equipment shall be capable of providing the following information locally to the Customer or Registrant for Stage 1 Metering Equipment; or to the Customer or Supplier for Stage 2 Metering Equipment, configured to their requirements taking account of the measured quantities (see clause 4.1.1):-

- (i) impulsing for Import kWh , Export kWh, Import kvarh, Export kvarh and kVAh -all to be voltage free contacts with a pulse rate at full load of between 0.1 and 2 pulses per second with a nominal duration of 80mS per pulse; and
- (ii) a 30 minute reset pulse, within a tolerance of +/- 0.1% of the Demand Period from voltage free contacts with a minimum duration of 0.5 seconds and a maximum duration of 10 seconds.

5.5 Outstation

An Outstation System shall be provided which transfers data to and receives data from a Settlement Instation.

Where a single separate Outstation is provided for storing data for more than one circuit, the Maximum Aggregated Capacity shall be 100 MVA.

Where more than one separate Outstation is provided, the main and check Meter data shall be stored in different Outstations.

The Outstation data shall be to a format and protocol approved by the Panel.

The Outstation shall facilitate the metering data to be read by instations other than the Settlement Instation provided the requirements of clause 7 of this Code of Practice are satisfied.

For the purpose of transferring stored metering data from the Outstation to the Settlement Instation, a unique Outstation identification code shall be provided.

Normally, metering data will be collected by the Settlement Instations by a daily interrogation, but repeat collections of metering data shall be possible throughout the Outstation data storage period.

If not integral, the Outstation System supply shall either be from a secure supply or from a measurement VT, with separate fusing for each Outstation.

Where a separate modem associated with the Outstation System is used, then it shall be provided with a separately fused supply either from a secure supply or from a measurement VT (see clause 5). Alternatively, line or battery powered modem types may be used.

5.5.1 Data Storage

Data storage facilities for metering data shall be provided as follows:-

- (i) Each Demand Value shall be identifiable to its respective date and time;
- (ii) a storage capacity of 48 periods per day for a minimum of 20 days for all demand values as defined in clause 4.1.2. The stored values shall be integer multiples of kW and kvar;
- (iii) the resolution of the Energy transferred into the demand registers shall be within $\pm 0.1\%$ (at full load) of the amount of Energy measured by the associated Meter;
- (iv) the value of any energy measured in a Demand Period but not stored in that Demand Period shall be carried forward to the next Demand Period;
- (v) where a separate Outstation is used, cumulative register values shall be provided in the Outstation which shall be set to match and increment with the Meter Registers;
- (vi) in the event of an Outstation supply failure, the Outstation shall protect all data stored up to the time of the failure, and maintain the time accuracy in accordance with clause 5.5.2;
- (vii) partial Demand Values, those in which an Outstation supply failure and/or restoration occurs, and zero Demand Values associated with an Outstation supply failure, shall be marked so that the Settlement Instation can identify them;
- (viii) to cater for continuous supply failures, the clock, calendar and all data shall be supported for a period of 20 days without an external supply connected;
- (ix) any "read" operation shall not delete or alter any stored metered data; and

- (x) an Outstation shall provide all of the metered data stored from the commencement of any specified date upon request by the Settlement Instation.

5.5.2 Time Keeping

- (i) The Outstation time shall be set to Co-ordinated Universal Time Clock (UTC). No switching between UTC and British Summer Time (BST) shall occur for Settlement data storage requirements.
- (ii) Time synchronisation of the Outstation may be performed remotely by the Settlement Instation as part of the normal interrogation process or locally by an Interrogation Unit.
- (iii) When time synchronisation occurs the relevant period(s) shall be marked with an alarm indication, as outlined in clause 5.5.3.
- (iv) The overall limits of error for the time keeping allowing for a failure to communicate with the Outstation for a period of 20 days shall be:-
 - a) the completion of each Demand Period shall be at a time which is within ± 20 seconds of UTC; and
 - b) the duration of each Demand Period shall be within $\pm 0.1\%$, except where time synchronisation has occurred in a Demand Period.

5.5.3 Monitoring Facilities

Monitoring facilities shall be provided for each of the following conditions and shall be reported, as separate alarm indications, tagged to the relevant Demand Period(s), via on-line communications and the local Interrogation Unit:-

- (i) phase failure of any one or combination of phases;
- (ii) Metering Equipment resets caused by other than a supply failure (where fitted);
- (iii) battery monitoring (where battery fitted);
- (iv) interrogation port access which changes time and/or date;
- (v) where different from (iv), Demand Period(s) which have been truncated or extended by a time synchronisation;
- (vi) interrogation port access which changes data other than time and/or date; and
- (vii) reverse running (if fitted).

In addition to (ii), detected errors in Metering Equipment functionality should be recorded as an event alarm with date and time.

Any alarm indications shall not be cancelled or deleted by the interrogation process and shall be retained with the data until overwritten. The alarm shall reset automatically when the abnormal condition has been cleared.

5.6 Communications

Outstation(s) shall provide both local and remote interrogation facilities, from separate ports.

To prevent unauthorised access to the data in the Metering Equipment a security scheme, as defined below and in Appendix D, and shall be incorporated for both local

and remote access. Separate security levels shall be provided for the following activities:-

(i) Level 1 - Password for:-

Read only of the following metering data, which shall be transferable on request during the interrogation process:-

- a) Outstation ID;
- b) Demand Values as defined in clause 4.1.2 for main and check Meters;
- c) cumulative measured quantities as defined in clause 4.1.1 for main and check Meters;
- d) Maximum Demand (MD) for kW or kVA per programmable charging period i.e. monthly, statistical review period;
- e) multi-rate cumulative Active Energy as specified by Registrant;
- f) the measurement transformer ratios, where appropriate (see clause 5.3);
- g) the measurement transformer error correction factor and/or system loss factor, where this is a constant factor applied to the entire dynamic range of the Meter and the Meter is combined with the display and/or Outstation;
- h) alarm indications; and
- i) Outstation time and date.

(ii) Level 2 - Password for:-

- a) corrections to the time and/or date; and
- b) resetting of the MD.

(iii) Level 3 - Password for:-

Programming of:-

- a) the Displays and Facilities as defined in clause 5.4;
- b) the measurement transformer ratios, as appropriate (see clause 5.3);
- c) the measurement transformer error correction and/or system loss factor where this is a constant factor applied to the entire dynamic range of the Meter and the Meter is combined with the display and/or Outstation; and
- d) the passwords for levels 1, 2 and 3.

In addition, it shall be possible to read additional information within the Metering Equipment to enable the programmed information to be confirmed.

(iv) Level 4 - Password or removal of Metering Equipment cover(s) necessitating the breaking of a seal for:-

- a) calibration of the Metering Equipment;
- b) setting the measurement transformer ratios, as appropriate;
- c) programming the measurement transformer error correction factor and/or system loss factor where this is other than a single factor; and

- d) programming the level 3 password and the level 4 password, if appropriate.

In addition to the functions specified for each level it shall be feasible to undertake the functions at the preceding level(s). e.g. at level 3 it shall also be possible to carry out the functions specified at levels 1 and 2. This need not apply at level 4 when access is obtained via removing the cover.

Different Passwords shall be utilised for each level, which shall only be circulated in accordance with the relevant BSC Procedure.

5.6.1 Local Interrogation

An interrogation port shall be provided for each Outstation which preferably shall be an opto port to BS EN 61107, and with a serial protocol such as BS EN 61107.

5.6.2 Remote Interrogation

Remote interrogation facilities shall be provided with error checking of the communications between the Outstation System and the Settlement Instation.

It shall not be possible to disconnect the remote communications connection to/from the Outstation without the breaking of an appropriate seal (see clause 5.7).

Interrogation of an Outstation shall be possible using one of the following media:

- (i) Switched telephone networks e.g. PSTN or CTN;
- (ii) Public data networks e.g. PSN;
- (iii) Radio data networks e.g. Paknet or any equivalent;
- (iv) Customer own network;
- (v) Mains signalling / power line carrier;
- (vi) Low power radio;
- (vii) Satellite; or
- (viii) Cable TV.

In addition any further media may be used as approved by the Panel.

The actual media employed shall be in accordance with the requirements of the CDCA for CVA Metering Systems and the Supplier for SVA Metering Systems..

The data shall be to a format and protocol approved by the Panel.

5.7 Appropriate Seals

All SVA Metering Equipment shall be sealed in accordance with Appendix 8 and 9 of the Meter Operator Code of Practice Agreement².

All CVA Metering Equipment shall be sealed using Settlement Seals and in accordance with BSCP06.

² The Meter Operator Code of Practice Agreement is a voluntary agreement between Public Distribution System Operators and Meter Operator Agents.

6. ASSOCIATED FACILITIES

6.1 Interrogation Unit

The operator may interrogate the Metering Equipment using an Interrogation Unit (IU). The IU may be used for programming, commissioning, maintenance/fault finding and when necessary the retrieval of stored metering data. The data retrieved by the IU shall be compatible with the Settlement Instation.

The IU shall have a built-in security system, such as a password, so that the IU becomes inoperative and non-interrogatable if it is lost, stolen, etc. The password can be applied at power-on of the device and/or on entry to the IU software application.

6.2 Additional Features

Additional features may be incorporated within or associated with the Metering Equipment provided but these shall not interfere with or endanger the operation of the Settlement process.

SUPERSEDED

7. ACCESS TO DATA

Access to metering data shall be in accordance with the provisions of the Code and the BSC Procedures referred to therein. Such access must not interfere with or endanger the security of the data or the collection process for Settlement purposes.

Access to stored metering data in Outstations shall also be the right of the Registrant and any party who has the permission of the Registrant.

SUPERSEDED

APPENDIX A DEFINED METERING POINTS

For transfers of electricity between the following parties the Defined Metering Point (DMP) shall be at one of the following locations:-

1. For transfers between the Transmission System Operator and a single Distribution System operated by a Licensed Distribution System Operator where no other Party(s) are connected to the busbar, the DMP shall be at the lower voltage side of the supergrid connected transformer.
2. For transfers between the Transmission System Operator and a single Distribution System operated by a Licensed Distribution System Operator where other Party(s) are connected to the busbar, the DMP shall be at the circuit connections to that Distribution System operated by a Licensed Distribution System Operator.
3. For transfers between the Transmission System Operator and more than one Distribution System operated by a Licensed Distribution System Operator connected to the same busbar, the DMP shall be at the circuit connections of each Distribution System operated by a Licensed Distribution System Operator to such busbar.
4. For transfers between Distribution Systems operated by Licensed Distribution System Operators not including a connection to the Transmission System, the DMP shall be at the point of connection of the two Distribution Systems operated by Licensed Distribution System Operators.
5. For transfers between the Transmission System and Generating Plant, the DMP shall be at the high voltage side of the generator transformers and station transformer(s).
6. For transfers between a Distribution System operated by a Licensed Distribution System Operator and Generating Plant, the DMP shall be at the point(s) of connection of the generating station to the Distribution System operated by the Licensed Distribution System Operator.
7. For transfers between the Distribution System of a Licensed Distribution System Operator a Customer, the DMP shall be at the point of connection to the Distribution System of the Licensed Distribution System Operator.
8. For transfers between the Transmission C System and a Customer, the DMP shall be at the point of connection to the Transmission System.

APPENDIX A (cont'd)

9. For transfers between the Transmission System and an External System the DMP shall be as follows:-
- (i) For the EdF link the busbar side of the busbar disconnectors at the Sellindge 400 kV Substation.
 - (ii) For the Moyle Interconnector, the Converter Station side of the L15 circuit breaker on the Coylton feeder at Auchencrosh Substation.

SUPERSEDED

APPENDIX B LABELLING OF METERS FOR IMPORT AND EXPORT

A standard method of labelling Meters, test blocks, etc is necessary and based on the definitions for Import and Export the required labelling shall be as follows.

1 ACTIVE ENERGY

Meters or Meter Registers shall be labelled "Import" or "Export" according to Figure 1.

2 REACTIVE ENERGY

Within the context of this code the relationship between Active Energy and Reactive Energy can best be established by means of the power factor. The following table gives the relationship:-

Flow of Active Energy	Power Factor	Flow of Reactive Energy
Import	Lagging	Import
Import	Leading	Export
Import	Unity	Zero
Export	Lagging	Export
Export	Leading	Import
Export	Unity	Zero

Meters or Meter Registers for registering Import Reactive Energy should be labelled "Import" and those for registering Export Reactive Energy should be labelled "Export".

APPENDIX B (cont'd)

FIGURE 1 IMPORT AND EXPORT ACTIVE ENERGY FLOWS CONVENTION

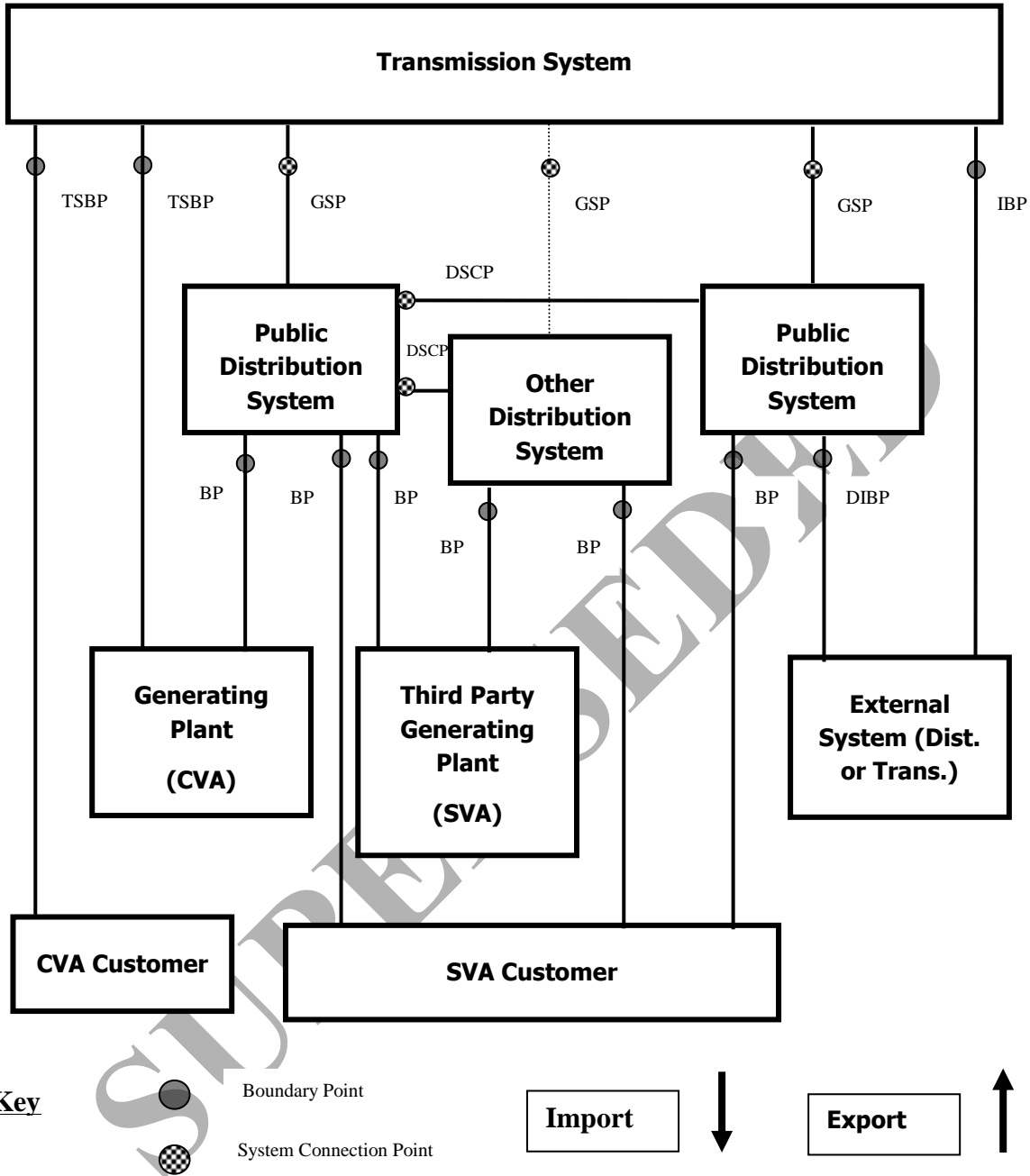

Import / Export Energy Flow Convention for the labelling of Meters

Import metering measures energy flows away from the Transmission System.

Export metering measures energy flows towards the Transmission System.

Energy flows between Distribution Systems is by bilateral agreement.

Key to abbreviations used in Import / Export Diagram

○	Metering Point
BP	Boundary Point
DIBP	Distribution Interconnector Boundary Point
DSCP	Distribution System Connection Point
GSP	Grid Supply Point
IBP	Interconnector Boundary Point
SCP	System Connection Point
TSBP	Transmission System Boundary Point

SUPERSEDED

APPENDIX C TYPICAL TESTING FACILITIES AND FUSING ARRANGEMENTS

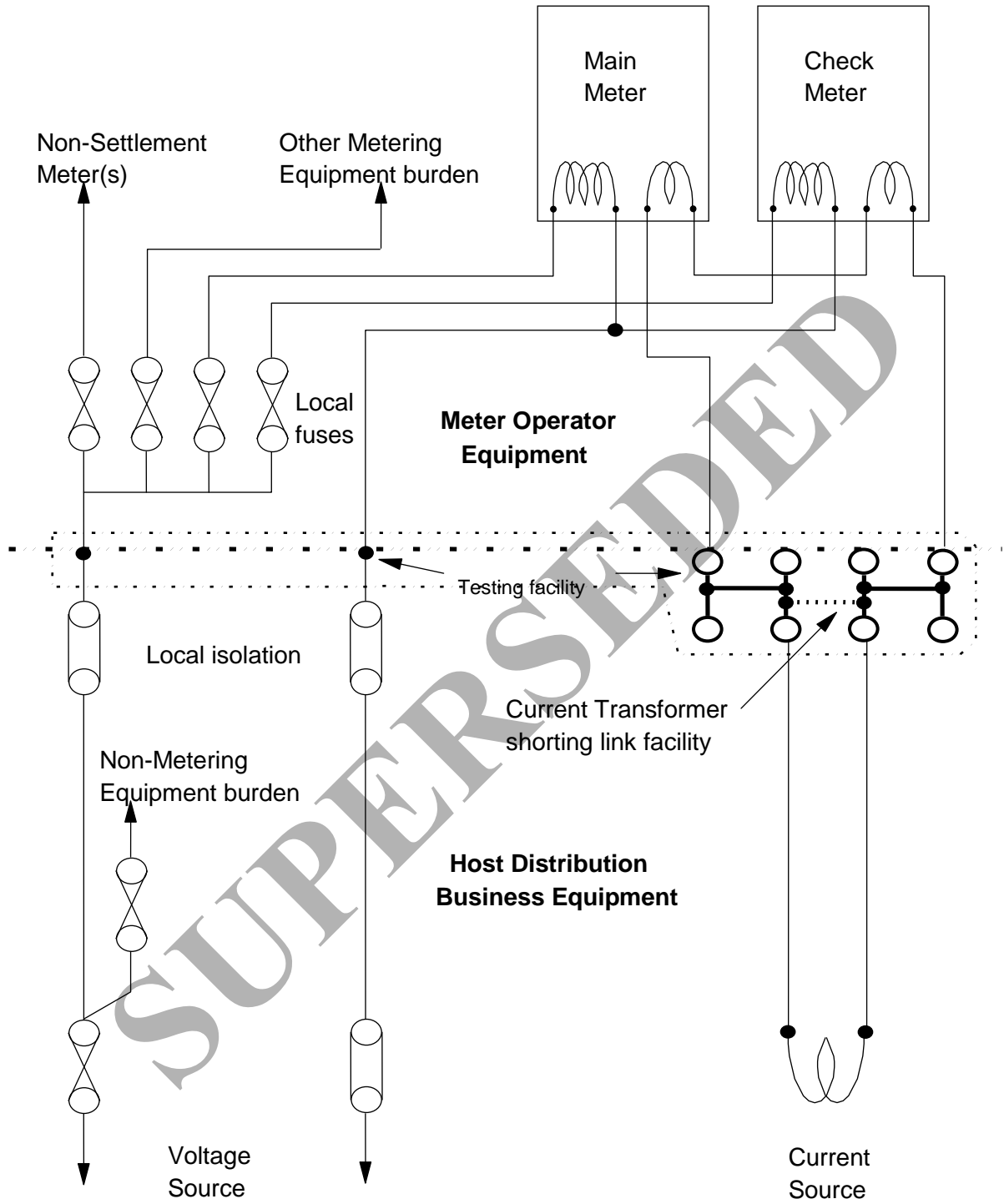

KEY:

- Boundary between Meter Operator Equipment and Host Distribution Business Equipment
- Testing Facilities

APPENDIX D PASSWORDS

The Passwords specified in clause 5.6 shall be subject to the following additional requirements:-

1. The communications protocol employed shall ensure that the Password offered determines the level of access to the data within the Metering Equipment.
2. A counter logging the number of illegal attempts (i.e. Password comparison failures) to access Metering Equipment via the local and remote ports shall be incorporated into the log-on process. This counter shall reset to zero at every hour change (i.e. 0100, 0200, etc.).
3. If the counter reaches 7, then access is prohibited at all levels until the counter resets at the next hour change.

SUPERSEDED

APPENDIX E OPTIONS FOR ENSURING METERS AND DISPLAYS CAN BE READ AND REMOTELY INTERROGATED

This Appendix sets out the options for complying with the requirements set out in clause 5 for certain types of supply where the voltage supply to the Metering Equipment would not normally be maintained for significant periods. e.g. those used for standby and those where the customer's restricted period load is controlled by the main incoming switchgear.

1. Connection of Metering Equipment to the Live Side of the Supply

For new supplies the most practical solution would be to arrange for the Metering Equipment to be connected to the incoming side of the main switchgear so that it is normally energised even when the switchgear is open.

2. Install Separate Meters and Displays/Outstations

Installation of separate Meters and Displays/Outstations would enable the latter to be connected to a normally energised supply. This would facilitate Local and Remote Interrogation and reading on a routine basis. The Meters would need to be provided with a permanent Meter Register to meet the requirements of clause 5.3.

3. Combined Meters, Displays and Outstations with Separate Auxiliary Supply Facilities

Integrated products could be utilised which have separate input terminals to energise the data storage and display functions which could be connected to a normally energised supply, whilst the voltage supply to the Meter is from the relevant circuit.

4. Combined Meters, Displays and Outstations Supplied via a Voltage Relay Selection Scheme

With this option the integrated equipment would be connected to an appropriate single phase voltage supply via a voltage relay selection scheme such that whilst this circuit was de-energised it would receive its voltage supply only, from the adjacent circuit. However, when this circuit was energised it would be fed with both voltage and current from the measured circuit. This arrangement is shown in Figure 2 overleaf and is only suitable for use with CT operated Metering Systems.

APPENDIX E (cont'd)

FIGURE 2 SCHEMATIC DIAGRAM SHOWING A TYPICAL VOLTAGE SELECTION RELAY SCHEME ON HV OR LV, NORMALLY DE-ENERGISED SUPPLIES, TO ENABLE METER READING (CT OPERATED METERING SYSTEMS ONLY).

