

Balancing and Settlement Code

Code of Practice Two

**CODE OF PRACTICE FOR THE METERING OF CIRCUITS WITH A
RATED CAPACITY NOT EXCEEDING 100 MVA FOR SETTLEMENT
PURPOSES.**

Issue 4

Version 12.0

DATE: 23 February 2017

Code of Practice Two

CODE OF PRACTICE FOR THE METERING OF CIRCUITS WITH A RATED CAPACITY NOT EXCEEDING 100 MVA FOR SETTLEMENT PURPOSES.

1. Reference is made to the Balancing and Settlement Code for the Electricity Industry in Great Britain and, in particular, to the definition of "Code of Practice" in Annex X-1 thereof.
2. This is Code of Practice Two, Issue 4, Version 12.0.
3. This Code of Practice shall apply to Metering Systems comprising Metering Equipment that are subject to the requirements of Section L of the Balancing and Settlement Code.
4. This Code of Practice is effective from 23 February 2017.
5. This Code of Practice has been approved by the Panel.

Superseded

Intellectual Property Rights, Copyright and Disclaimer

The copyright and other intellectual property rights in this document are vested in ELEXON or appear with the consent of the copyright owner. These materials are made available for you for the purposes of your participation in the electricity industry. If you have an interest in the electricity industry, you may view, download, copy, distribute, modify, transmit, publish, sell or create derivative works (in whatever format) from this document or in other cases use for personal academic or other non-commercial purposes. All copyright and other proprietary notices contained in the document must be retained on any copy you make.

All other rights of the copyright owner not expressly dealt with above are reserved.

No representation, warranty or guarantee is made that the information in this document is accurate or complete. While care is taken in the collection and provision of this information, ELEXON Limited shall not be liable for any errors, omissions, misstatements or mistakes in any information or damages resulting from the use of this information or action taken in reliance on it.

AMENDMENT RECORD

Issue	Version	Date	Description of Changes	Changes Included	Mods/ Panel/ Committee Refs
Draft	0.03	18/3/93	Recommended to PEC; MSC		
1	1.00	15/4/93	Endorsed by PEC; CoP WG		
2	1.03	01/5/97	Amendments for 100kW Take-on; 1998 Programme		
3	1.05	1998 Operational Date	Amended following review by Expert Group and internally; 1998 Programme (C A Team)		
3	1.05	Code Effective Date ¹	Re-badging of Code of Practice Two for the implementation of the Balancing and Settlement Code; BSCCo (Elexon Limited)		Panel 16/11/00 (Paper 07/003)
3	2.0	BETTA Effective Date	Rebadging changes for the CVA Feb 05 Release; BSCCo	BETTA 6.3	
4	3.0	23/02/06	February 06 Release; BSCCo	CP1051	ISG55/001
4	4.0	06/11/08	November 08 Release; BSCCo	CP1232, CP1238	ISG88/01 SVG88/02
4	5.0	25/06/09	June 09 Release; BSCCo	CP1264	ISG94/01 SVG94/02
4	6.0	05/11/09	BSCCo	CP1289	ISG101/01
4	7.0	20/11/09	Modification P238; BSCCo		Panel 160/05
4	8.0	26/11/09	Modification P230; BSCCo		Panel 153/03
4	9.0	24/06/10	June 10 Release	CP1324	ISG111/03
4	10.0	23/02/12	February 12 Release	P266 CP1349	ISG130/08 ISG127/05
4	11.0	26/02/15	February 15 Release	CP1422	ISG163/01 SVG166/06
4	12.0	23/02/17	February 17 Release	CP1470	ISG185/02 SVG188/04

¹ "Code Effective Date" means the date of the Framework Agreement.

**CODE OF PRACTICE FOR THE METERING OF CIRCUITS WITH A RATED
CAPACITY NOT EXCEEDING 100MVA FOR SETTLEMENT PURPOSES.**

FOREWORD	5
1. SCOPE	6
2. REFERENCES	7
3. DEFINITIONS AND INTERPRETATIONS	8
4. MEASUREMENT CRITERIA	13
4.1 Measured Quantities and Demand Values for Metering Systems Registered in CMRS	13
4.1.1 Measured Quantities	13
4.1.2 Demand Values	13
4.2 Measured Quantities and Demand Values for Metering Systems Registered in SMRS	13
4.2.1 Measured Quantities	13
4.2.2 Demand Values	14
4.3 Accuracy Requirements	15
4.3.1 Overall Accuracy	15
4.3.2 Compensation for Measurement Transformer Error	15
4.3.3 Compensation for Power Transformer and Line Losses	16
5. METERING EQUIPMENT CRITERIA	17
5.1 Measurement Transformers	17
5.1.1 Current Transformers	17
5.1.2 Voltage Transformers	18
5.1.3 Monitoring of Voltage Transformers	18
5.1.4 Measurement Transformers Installed on Existing Circuits	18
5.2 Testing Facilities	18
5.3 Meters	19
5.4 Displays and Facilities for Registrant or Supplier Information	20
5.4.1 Displays	20
5.4.2 Facilities	21
5.5 Outstation	21
5.5.1 Data Storage	22
5.5.2 Time Keeping	23
5.5.3 Monitoring Facilities	23
5.6 Communications	23
5.6.1 Local Interrogation	25
5.6.2 Remote Interrogation	25
5.7 Sealing	26
6. ASSOCIATED FACILITIES	27
6.1 Interrogation Unit	27
6.2 Additional Features	27
7. ACCESS TO DATA	27
APPENDIX A: DEFINED METERING POINTS	28
APPENDIX B: LABELLING OF METERS FOR IMPORT AND EXPORT	30
APPENDIX C: FUSING	34
APPENDIX D: PASSWORDS	36
APPENDIX E: GUIDANCE FOR THE USE OF MULTI CORE METERING CABLES	37
APPENDIX F: GUIDANCE FOR THE COMMUNICATION ARRANGEMENTS FOR METERING SYSTEMS LOCATED OFFSHORE AT OFFSHORE POWER PARK MODULES	38

FOREWORD

This Code of Practice defines the minimum requirements for the Metering Equipment required for the measurement and recording of electricity transfers at Defined Metering Points where the rated circuit capacity does not exceed 100MVA.

For the purpose of this Code of Practice the rated circuit capacity in MVA shall be determined by the lowest rated primary plant (e.g. transformer rating, line rating, etc) of the circuit. The Metering Equipment provision and accuracy requirements shall anticipate any future up-rating consistent with the installed primary plant. The primary plant maximum continuous ratings shall be used in this assessment.

For the purpose of this Code of Practice, the use of summation current transformers shall not be permitted. The use of interposing current transformers is permitted provided the overall Metering System accuracy is maintained.

Where a material change to a Metering System takes place, then this Metering System must be modified to comply with the most recent version of this Code of Practice. Changes to a Metering System are considered to be material where they constitute a change to:

- i. Switchgear containing measurement transformers; and/or
- ii. The primary plant associated with the Metering System i.e. the measurement transformers.

Where a Metering Dispensation applies, and where the Actual Metering Point is not at the Defined Metering Point, a material change affecting the Defined Metering Point may not affect the Metering System at the Actual Metering Point.

BSCCo shall retain copies of, inter alia, the Code of Practice together with copies of all documents referred to in them, in accordance with the provisions of the Balancing and Settlement Code (the Code).

1. SCOPE

This Code of Practice states the practices that shall be employed, and the facilities that shall be provided for the measurement and recording of the quantities required for Settlement purposes on each circuit where the rated capacity does not exceed 100MVA.

It derives force from the Code, and in particular the metering provisions (Section L), to which reference should be made. It should also be read in conjunction with any relevant BSC Procedures.

Metering Equipment that meets the requirements of this Code of Practice is also applicable where the Registrant is required by its Supply Licence (and as referenced in Section L 3.2.6) to install Metering Equipment that is capable of providing measured electricity consumption data for multiple periods (at least half hourly) and providing the Registrant with remote access to such data.

This Code of Practice does not contain the calibration, testing and commissioning requirements for Metering Equipment used for Settlement purposes. These requirements are detailed in Code of Practice Four - "Code of Practice for Calibration, Testing and Commissioning Requirements for Metering Equipment for Settlement Purposes".

Metering Dispensations from the requirements of this Code of Practice may be sought in accordance with the Code and BSCP32.

Meters and Outstations referred to in this Code of Practice shall only achieve successful compliance in respect of any testing detailed in this Code of Practice if the requirements set out in accordance with BSCP601 are also observed and successfully completed or the Registrant has been granted a valid Metering Dispensation covering any departure from the requirements as detailed in this Code of Practice.

In the event of an inconsistency between the provisions of this Code of Practice and the Code, the provisions of the Code shall prevail.

2. REFERENCES

The following documents are referred to in the text:-

BS EN 50470 – 3	Electricity metering equipment (a.c.) - Part 3: Particular requirements – Static meters for active energy (class indexes A, B and C)
BS EN 60044-3	Instrument transformers. Combined transformers
BS EN 62053-11	Electricity metering equipment (a.c.). Particular requirements. Electromechanical meters for active energy (classes 0.5, 1 and 2)
BS EN 62053-22	Electricity metering equipment (a.c.). Particular requirements. Static meters for active energy (classes 0.2 S and 0.5 S)
BS EN 62053-23	Electricity metering equipment (a.c.). Particular requirements. Static meters for reactive energy (classes 2 and 3)
BS EN 62056-21	Electricity metering. Data exchange for meter reading, tariff and load control. Direct local data exchange
BS 5685 Part 4	Specification for Class 3 Var-Hour Meters
IEC 60044-1	Instrument transformers. Current transformers
IEC 60044-2	Instrument transformers. Inductive voltage transformers
Balancing and Settlement Code	Definitions, Section X; Annex X-1 and Section L and BSC Procedures
Code of Practice Four	Code of Practice for Calibration, Testing and Commissioning Requirements for Metering Equipment for Settlement Purposes
BSC Procedures	BSCP06, BSCP32, BSCP601
Electricity Act 1989	Schedule 7 as amended by Schedule 1 to the Competition and Services (Utilities) Act 1992.

3. DEFINITIONS AND INTERPRETATIONS

Save as otherwise expressly provided herein, words and expressions used in this Code of Practice shall have the meanings attributed to them in the Code and are included for the purpose of clarification.

Note: * indicates definitions in the Code.

Note: † indicates definitions which supplement or complement those in the Code.

Note: ‡ indicates definitions specific to this Code of Practice

3.1 Active Energy *

Active Energy means the electrical energy produced, flowing or supplied by an electrical circuit during a time interval, being the integral with respect to time of the instantaneous Active Power, measured in units of watt-hours or standard multiples thereof.

3.2 Active Power *

Active Power means the product of voltage and the in-phase component of alternating current measured in units of watts and standard multiples thereof, that is:-

$$1,000 \text{ Watts} = 1 \text{ kW}$$

$$1,000 \text{ kW} = 1 \text{ MW}$$

3.3 Actual Metering Point ‡

Actual Metering Point means the physical location at which electricity is metered.

3.4 Apparent Energy ‡

Apparent Energy means the integral with respect to time of the Apparent Power.

3.5 Apparent Power ‡

Apparent Power means the product of voltage and current measured in units of voltamperes and standard multiples thereof, that is:-

$$1,000 \text{ VA} = 1 \text{ kVA}$$

$$1,000 \text{ kVA} = 1 \text{ MVA}$$

3.6 Communication Line ‡

Communication Line means a line or link whose components are dedicated to a single Outstation System. A Communication Line shall be identified by a unique number, e.g. CTN line number 123, PSTN line number 321 or IP address 555. Communication Lines may comprise electrical circuits, optical fibres, radio links, or any other permitted media which allows data to be collected remotely on demand by a Data Collector or Meter Operator using an approved protocol.

3.7 CTN ‡

CTN means the Electricity Supply Industry (ESI) corporate telephone network.

3.8 CVA †

CVA means "Central Volume Allocation".

3.9 CVA Customer †

CVA Customer means any customer, receiving electricity directly from the Transmission System, irrespective of from whom it is supplied.

3.10 Defined Metering Point ‡

Defined Metering Point means the physical location at which the overall accuracy requirements as stated in this Code of Practice are to be met. The Defined Metering Points are identified in Appendix A.

3.11 Demand Period ‡

Demand Period means the period over which Active Energy, Reactive Energy or Apparent Energy are integrated to produce Demand Values. For Settlement purposes, each Demand Period shall be of 30 minutes duration, one of which shall finish at 24:00 hours.

3.12 Demand Values ‡

Demand Values means, expressed in MW, Mvar or MVA, twice the value of MWh, Mvarh or MVAh recorded during any Demand Period². The Demand Values are half hour demands and these are identified by the time of the end of the Demand Period.

3.13 electricity *

"electricity" means Active Energy and Reactive Energy.

3.14 Export †

Export means, for the purposes of this Code of Practice, an electricity flow as indicated in Figure 1 of Appendix B.

3.15 Import †

Import means, for the purposes of this Code of Practice, an electricity flow as indicated in Figure 1 of Appendix B.

² Please note that these Demand Values are for use with CVA Metering Systems. SVA Metering Systems shall use units a factor of 103 smaller than CVA e.g. kW rather than MW.

3.16 Interrogation Unit ‡

Interrogation Unit means a Hand Held Unit "HHU" (also known as Local Interrogation Unit "LIU") or portable computer which can enter Outstation parameters and extract information from the Outstation and store this for later retrieval.

3.17 Maximum Aggregated Capacity ‡

The maximum aggregated capacity for multiple circuits shall be determined for:-

- (i) Generator circuits, by the summation of the capacities of the lowest primary plant rating for each circuit.
- (ii) Network or customer circuits all of equal rating, by multiplying the lowest primary plant rating of one circuit by one less than the number of circuits involved, e.g. number of circuits (n) = 3, factor = $n - 1 = 2$.
- (iii) Network or customer circuits of different ratings, (all of which must be under 100 MVA) by summation of the lowest plant rating for each circuit ignoring the highest rated circuit e.g. 3 circuits rated at 45 MVA, 40 MVA, 35 MVA, rating = 75 MVA.

3.18 Meter *

Meter means a device for measuring Active Energy and/or Reactive Energy.

3.19 Metering Equipment *

Metering Equipment means Meters, measurement transformers (voltage, current and combination units), metering protection equipment including alarms, circuitry, their associated Communications Equipment and Outstations, and wiring.

3.20 Meter Register ‡

Meter Register means a device, normally associated with a Meter, from which it is possible to obtain a reading of the amount of Active Energy, or the amount of Reactive Energy that has been supplied by a circuit.

3.21 Offshore Platform ‡

Has the meaning given to that term in the Grid Code.

3.22 Offshore Power Park Module *

Has the meaning given to that term in the Grid Code.

3.23 Outstation *

Outstation means equipment which receives and stores data from a Meter(s), for the purposes, inter-alia, of transfer of that metering data the Central Data Collector Agent (CDCA) or Data Collector, as the case may be, and which may perform some processing before such transfer and may be in one or more separate units or may be integral with the Meter.

3.24 Outstation System ‡

Outstation System means one or more Outstations linked to a single communication line.

3.25 PARh Meter ‡

PARh Meter means a phase-advanced reactive hour (PARh) Meter which is used for obtaining Import and Export Reactive Energy from one integrating Meter. The Reactive Energy Demand values shall be calculated using a formula involving the PARh Meter and the associated Active Energy Meter Demand Values.

3.26 Password ‡

For Meters with integral Outstations: 'Password' means a string of characters of length no less than six characters and no more than twelve characters, where each character is a case insensitive or sensitive alpha character (A to Z) or a digit (0 to 9) or the underscore character (_). Passwords must have a minimum of 2,000,000 combinations, for example six characters if composed of any alphanumeric characters or eight characters if composed only of hexadecimal characters (0 to F). The characters of a hexadecimal password must be in upper case.

For separate Outstations: a Password may be described as above for integral Outstations or a single password of any format³.

3.27 PSTN ‡

PSTN means the public switched telephone network.

3.28 Rated Measuring Current ‡

Rated Measuring Current means the rated primary current of the current transformers in primary plant used for the purposes of measurement.

3.29 Reactive Energy *

Reactive Energy means the integral with respect to time of the Reactive Power and for the purpose of the Code, is comprised of Active Export Related Reactive Energy and Active Import Related Reactive Energy.

3.30 Reactive Power *

Reactive Power means the product of voltage and current and the sine of the phase angle between them measured in units of voltamperes reactive and standard multiples thereof.

³ Meters separate from their Outstation and capable of external communications should have the same password requirements as for separate Outstations.

3.31 Registrant *

Registrant means in relation to a Metering System, the person for the time being registered in CMRS or (as the case may be) SMRS in respect of that Metering System pursuant to Section K of the Balancing and Settlement Code.

3.32 Settlement Instation ‡

Settlement Instation means a computer based system which collects or receives data on a routine basis from selected Outstation Systems by as Data Collector.

3.33 SVA †

SVA means "Supplier Volume Allocation".

3.34 SVA Customer *

SVA Customer means a person to whom electrical power is provided, whether or not that person is the provider of that electrical power; and where that electrical power is measured by a SVA Metering System.

3.35 UTC *

UTC means Co-ordinated Universal Time which bears the same meaning as in the document Standard Frequency and Time Signal Emission, International Telecommunication Union - RTF.460 (ISBN92-61-05311-4) (colloquially referred to as Rugby Time).

4. MEASUREMENT CRITERIA

The following measured quantities and Demand Values are for use with CVA Metering Systems.

4.1 Measured Quantities and Demand Values for Metering Systems Registered in CMRS

4.1.1 Measured Quantities

For each separate circuit the following energy measurements are required for Settlement purposes:

- (i) Import MWh *
- (ii) Export MWh *
- (iii) Import Mvarh
- (iv) Export Mvarh

4.1.2 Demand Values

For each Demand Period for each circuit the following Demand Values shall be provided:

- (i) Import MW *
- (ii) Export MW *
- (iii) Import Mvar
- (iv) Export Mvar

* Import or Export metering need only be installed where a Party requires this measurement to meet system or plant conditions.

4.2 Measured Quantities and Demand Values for Metering Systems Registered in SMRS

SVA Metering Systems shall use units a factor of 10^3 smaller than CVA i.e. kWh rather than MWh.

4.2.1 Measured Quantities

For each separate circuit the following energy measurements are required for Settlement purposes:-

- (i) Import kWh *
- (ii) Export kWh *
- (iii) Active Import related Import kvarh

- (iv) Active Import related Export kvarh
- (v) Active Export related Import kvarh
- (vi) Active Export related Export kvarh

4.2.2 Demand Values

For each Demand Period for each circuit the following Demand Values shall be provided:-

- (i) Import kW *
- (ii) Export kW *
- (iii) Active Import related Import kvar
- (iv) Active Import related Export kvar
- (v) Active Export related Import kvar
- (vi) Active Export related Export kvar

* Import or Export metering need only be installed where a Party requires this measurement to meet system or plant conditions. However both Import and Export reactive measurements shall be provided for each Active measurement.

4.3 Accuracy Requirements

4.3.1 Overall Accuracy

The overall accuracy of the energy measurements at or referred to the Defined Metering Point shall at all times be within the limits of error as shown:-

(i) Active Energy

CONDITION	LIMIT OF ERRORS AT STATED SYSTEM POWER FACTOR	
	Power Factor	Limits of Error
Current expressed as a percentage of Rated Measuring Current		
120% to 10% inclusive	1	± 1.0%
Below 10% to 5%	1	± 1.5%
Below 5% to 1%	1	± 2.5%
120% to 10% inclusive	0.5 lag and 0.8 lead	± 2.0%

(ii) Reactive Energy

CONDITION	LIMIT OF ERRORS AT STATED SYSTEM POWER FACTOR	
	Power Factor	Limits of Error
Current expressed as a percentage of Rated Measuring Current		
120% to 10% inclusive	Zero	± 4.0%
120% to 20% inclusive	0.866 lag and 0.866 lead	± 5.0%

These limits of error for both (i) and (ii) above shall apply at the Reference Conditions defined in the appropriate Meter specification.

Evidence to verify that these overall accuracy requirements are met shall be available for inspection by either the Panel or the Technical Assurance Agent.

4.3.2 Compensation for Measurement Transformer Error

To achieve the overall accuracy requirements it may be necessary to compensate Meters for the errors of the measurement transformers and the associated leads to the Meters. Values of the compensation shall be recorded and evidence to justify the

compensation criteria, including wherever possible test certificates, shall be available for inspection by either the Panel or the Technical Assurance Agent.

4.3.3 Compensation for Power Transformer and Line Losses

Subject to Appendix A paragraph 5(ii) where the Actual Metering Point and the Defined Metering Point do not coincide a Metering Dispensation shall be applied for and, where necessary, accuracy compensation for power transformer and/or line losses shall be provided to meet the overall accuracy at the Defined Metering Point. Where Appendix A paragraph 5(ii) applies a Metering Dispensation shall not be required and accuracy compensation for power transformer and/or line losses (for the purpose of Section K1.1.6 of the Code) shall be provided or applied to meet the overall accuracy required at the Defined Metering Point.

The accuracy compensation may be achieved in the Metering Equipment and in this event the provided or applied values shall be recorded. Supporting evidence to justify the accuracy compensation criteria shall be available for inspection by either the Panel or the Technical Assurance Agent.

Alternatively, the accuracy compensation may be provided or applied in the software of the relevant data aggregation system used for Settlement purposes. In this event the factors shall be passed to the appropriate agency and evidence to justify the accuracy compensation criteria shall be made available for inspection by either the Panel or the Technical Assurance Agent.

5. METERING EQUIPMENT CRITERIA

Although for clarity this Code of Practice identifies separate items of equipment, nothing in it prevents such items being combined to perform the same task provided the requirements of this Code of Practice are met.

Metering Equipment other than outdoor measurement transformers shall be accommodated in a clean and dry environment.

5.1 Measurement Transformers

For each circuit current transformers (CT) and voltage transformers (VT) shall meet the requirements set out in clauses 5.1.1 and 5.1.2.

Additionally, where a combined unit measurement transformer (VT & CT) is provided the 'Tests for Accuracy' as covered in BS EN 60044-3 covering mutual influence effects shall be met.

All measurement transformers shall be of a wound construction.

For Metering Systems that represent low burdens on measurement transformers, consideration shall be given as to whether that operating burden is within the operating range of the measurement transformers. In such cases, it may be necessary to add additional burden.

Guidance for the use of multi core cables is provided in Appendix E.

5.1.1 Current Transformers

A dedicated set of current transformers in accordance with IEC 60044-1 and with a minimum standard of accuracy to Class 0.2S (irrespective of the secondary current rating of the CTs) shall be provided solely for the Settlement Metering of each circuit. No other burden shall be connected to this dedicated set of current transformers. The main Meter shall always be connected to this dedicated set of current transformers. The check Meter may also be connected to this dedicated set of current transformers.

Alternatively the check Meter may be connected to another set of current transformers which shall be in accordance with IEC 60044-1 and with a minimum standard of accuracy to Class 0.2S. Other burdens may be connected to this other set of current transformers provided that the Panel or Technical Assurance Agent is notified and that the overall accuracy requirements in clause 4.3.1 are met and evidence of the value of the additional burden shall be available for inspection by the Panel. The additional burden shall not be modified without prior notification to the Panel, and evidence of the value of the modified additional burden shall be available for inspection by either the Panel or Technical Assurance Agent.

CT test certificates showing errors at the overall working burden or at burdens which enable the working burden errors to be calculated shall be available for inspection by either the Panel or the Technical Assurance Agent.

The total burden on each current transformer shall not exceed the rated burden of such CT.

5.1.2 Voltage Transformers

Voltage transformer primary windings shall be connected to the circuit being measured for Settlement purposes and a dedicated secondary winding shall be provided for the main and check metering. The voltage transformer secondary winding shall be in accordance with IEC 60044-2 and with a minimum standard of accuracy to Class 0.5. Where a voltage transformer has other secondary windings these may be used for the check metering of that circuit and for other purposes provided the overall accuracy requirements in clause 4.3.1 are met and evidence of the value of the additional burden is available for inspection by either the Panel or the Technical Assurance Agent.

The additional burden shall not be modified without prior notification to the Panel, and evidence of the value of the modified additional burden shall be available for inspection by either the Panel or the Technical Assurance Agent.

A VT test certificate(s) showing errors at the overall working burden(s) or at burdens which enable the working burden errors to be calculated shall be available for inspection by either the Panel or the Technical Assurance Agent.

The total burden on each secondary winding of a VT shall not exceed the rated burden of such secondary winding.

5.1.3 Monitoring of Voltage Transformers

Where a common mode fault, such as a VT fuse failure, could cause incorrect voltages on both the main and check Meters, Meters combining integral Outstations shall provide for the data to be identified with an alarm indicating phase failure.

For separate Outstations, an alarm may be used which shall incorporate a time delay feature so as to avoid spurious operation. This alarm shall provide notification of a phase failure by the next Working Day at a point which is normally manned.

A spare channel on the Outstation or any other available means may be used to transmit the alarm.

5.1.4 Measurement Transformers Installed on Existing Circuits

Where circuits, other than those newly installed, are to be metered to this Code of Practice and where the installed measurement transformers do not comply fully with clauses 5.1.1 & 5.1.2, then such measurement transformers may be used providing the requirements in clauses 4.3.1 and 5.1.3 are met.

5.2 Testing Facilities

Separate testing facilities shall be provided for the main Meters and for the check Meters of each circuit, which enables such Meters to be routinely tested and/or changed safely with the circuit energised. The test facilities shall be nearby the Meters involved.

5.3 Meters

The Meters may be either static or induction disc types.

For each circuit main and check Active Energy Meters shall be supplied. These Meters shall meet the requirements of either BS EN 62053-22 Class 0.5S or BS EN 50470-3 Class C, or BS EN 62053-11 class 0.5 except where the overall accuracy as defined in Clause 4.3.1 is required in the range "Below 5% to 1%" of Rated Measuring Current. Subject to the agreement of the Panel or Registrant where system or plant conditions permit either the Import or Export Meters may be omitted.

All Meters shall be set to the actual primary and secondary ratings of the measurement transformers and the actual ratios displayed on the display or nameplate of the Meter.

Active Energy Meters provided for the metering of supplies to customers shall be in accordance with Schedule 7 of the Electricity Act 1989.

For each circuit only main Reactive Energy Meter(s) need be supplied. The Reactive Energy Meters shall meet the requirements of either BS EN 62053-23 Class 3.0 or BS 5685 Part 4.

For existing metering installations a Reactive Meter connected in a PARh Meter configuration may be retained.

Active Energy Meters shall be configured such that the number of measuring elements is equal to or one less than the number of primary system conductors. These include the neutral conductor, and/or the earth conductor where system configurations enable the flow of zero sequence energy.

All Meters shall be labelled or otherwise be readily identifiable in accordance with Appendix B.

All Meters shall include a non-volatile Meter Register of cumulative energy for each measured quantity. The Meter Register(s) shall not roll-over more than once within the normal Meter reading cycle.

Meters which provide data to separate Outstations shall for this purpose provide an output per measured quantity.

For Meters using electronic displays due account shall be given to the obligations of the Central Data Collection Agent (CDCA) or other Data Collectors to obtain Meter readings. For example, where a Metering System is employed on multiple circuits, a Voltage Selector Relay or other similar method should be used to maintain the Meter display in the event of a circuit being de-energised where this is reasonably practical.

Fusing shall be placed as close as practicable to the VT. In addition, means of isolation shall be provided locally for each Meter, any additional burden and their associated test facilities in accordance with Appendix C.

5.4 Displays and Facilities for Registrant or Supplier Information

5.4.1 Displays

The Metering Equipment shall display the following primary information (not necessarily simultaneously):

- (i) Mandatory Displays
 - (a) Measured quantities as per clause 4.1.1;
 - (b) Current time (“UTC”) and date;
 - (c) Measurement transformer ratios (see clause 5.3); and
 - (d) Any compensation factor which has been applied for measurement transformer errors and/or system losses, where this is a constant factor⁴ applied at security level 3 (i.e. where the Meter is combined with the display and/or Outstation).

Metering Equipment shall also be capable of displaying the following information, as specified by the Registrant.

- (ii) Display capabilities
 - (a) Maximum Demand (MD) for kW or MW as appropriate per programmable charging period i.e. monthly or statistical review period;
 - (b) Maximum Demand (MD) for kVA or MVA as appropriate per programmable charging period i.e. monthly or statistical review period;
 - (c) Twice the kWh advance or MWh advance as appropriate since the commencement of a current Demand Period (i.e. kW or MW rising demand);
 - (d) Twice the kVAh advance or MVAh advance as appropriate since the commencement of a current Demand Period (i.e. kVA or MVA riding demand);
 - (e) Cumulative MD;
 - (f) Number of resets; and
 - (g) Multi-rate display sequence as specified by the Registrant with a minimum of 8 rates selectable over the calendar year

MD shall be resettable at midnight of the last day of the charging period and for part chargeable period demands. If a manual reset button is provided then this shall be sealable.

⁴ N.B. This excludes cases where a dynamic range of compensation factors have been applied.

5.4.2 Facilities

The Metering Equipment shall be capable of providing the following information locally to the Customer or Registrant configured to their requirements taking account of the measured quantities (see clause 4.1.1):

- (i) For Active energy in MWh or kWh as appropriate (Import and Export), reactive energy in Mvarh or kVARh as appropriate (Import and Export) – if volt-free contacts are used, then these should use a pulse rate at full load of at least 1000 per Settlement Period with a nominal duration of 80ms per pulse; and
- (ii) A 30 minute reset pulse, and if volt-free contacts are used then this pulse should be within a tolerance of $\pm 0.1\%$ of the Demand Period from the volt-free contacts with a minimum duration of 80ms.

5.5 Outstation

One Outstation System shall be provided which can be interrogated by Settlement Instations. The Outstation system shall comprise either a single separate Outstation or the use of Meters with integral Outstations (i.e. a main or check Meter storing its own data).

Where one or more separate Outstations are provided each Outstation shall store the main and check Meter data for one or more circuits up to a Maximum Aggregated Capacity of 100 MVA. Separate Outstations storing data from a number of different circuits may be cascaded on to one Communication Line.

Metering Systems comprising Meters with integral Outstations need not store data from the associated main or check Meter providing that each Outstation has separate communications.

For Metering Systems located Offshore at Offshore Power Park Modules duplicate Outstation Systems with separate Communication Lines shall be provided. Main and check data shall be accessible using either of the separate Communication Lines. A single point of failure in the communication path between an instation and an Outstation shall not prevent access to main and check metering data stored in required Outstations. Appendix F shows some examples of arrangements for Offshore Power Park Modules.

The Outstation data shall be to a format and protocol approved by the Panel in accordance with BSCP601.

The Outstation shall have the ability to allow the metering data to be read by instations other than the Settlement Instation provided the requirements of Section 7 of this Code of Practice are satisfied.

Facilities shall be provided to select a relevant demand period from one of the following values:-

30, 20, 15, 10 and 5 minutes with in each case one demand period ending on the hour.

Normally metering data will be collected by the Settlement Instations by a daily interrogation, but repeat collections of metering data shall be possible throughout the Outstation data storage period.

Outstations, that are not exclusive to one circuit, shall be fitted with an auxiliary terminal that provides for the Outstation's energisation for remote interrogation purposes. The supply to the auxiliary terminal shall be free of switches and secure, and may be provided from the measurement VT as long as it is separate from the potential measurement circuits at source.

Where a separate modem associated with the Outstation System is used, then it shall be provided with a separately fused supply either from a secure supply or from a measurement VT. Alternatively, line or battery powered modem types may be used.

Where a measurement VT source is used and the Outstation System is storing data for more than one circuit, a VT selection relay scheme involving each circuit shall be provided.

Preferably the Outstation shall be able to continue all normal functions for a period of 120 hours after a supply failure. Outstations not providing this facility must in the event of a supply failure transmit an alarm signal to a manned point.

The Outstation shall not convert PARh metering data to vars.

5.5.1 Data Storage

Data storage facilities for metering data shall be provided as follows:-

- (i) A storage capacity of 48 periods per day for a minimum of 10 days for all Demand Values.
- (ii) The stored Demand Values shall be integer values of kW/MW or kvar/Mvar as appropriate, or pulse counts, and have a resolution of better than $\pm 0.1\%$ (at full load);
- (iii) The accuracy of the energy values derived from Demand Values shall be within $\pm 0.1\%$ (at full load) of the amount of energy measured by the associated Meter;
- (iv) The value of any energy measured in a Demand Period but not stored in that Demand Period shall be carried forward to the next Demand Period;
- (v) Where a separate Outstation is used, cumulative register values shall be provided in the Outstation which can be set to match and increment with the Meter Registers;
- (vi) In the event of an Outstation supply failure, the Outstation shall protect all data stored up to the time of the failure, and maintain the time accuracy in accordance with clause 5.5.2;
- (vii) Partial Demand Values, those in which an Outstation supply failure and/or restoration occurs, and zero Demand Values associated with an Outstation

supply failure, shall be marked so that the Settlement Instation can identify them;

- (viii) To cater for continuous supply failures, the clock, calendar and all data shall be supported for a period of 10 days without an external supply connected;
- (ix) Any "read" operation shall not delete or alter any stored metered data; and
- (x) An Outstation shall provide all of the metered data stored from the commencement of any specified date upon request by the Settlement Instation.

5.5.2 Time Keeping

- (i) The Outstation time shall be set to Co-ordinated Universal Time (UTC). No switching between UTC and British Summer Time (BST) shall occur for Settlements data storage requirements.
- (ii) Time synchronisation of the Outstation shall only be performed by communication with the Settlement Instation.
- (iii) The overall limits of error for the time keeping allowing for a failure to communicate with the Outstation for an extended period of 10 days shall be:-
 - (a) the completion of each Demand Period shall be at a time which is within ± 10 seconds of UTC; and
 - (b) the duration of each Demand Period shall be within $\pm 0.1\%$, except where time synchronisation has occurred in a Demand Period.

5.5.3 Monitoring Facilities

Monitoring facilities shall be provided for each of the following conditions and shall be reported, tagged wherever possible to the relevant Demand Period(s), via the local interrogation facility:-

- (i) Error in Outstation functionality;
- (ii) Battery monitoring (where battery fitted); and
- (iii) Interrogation port access which changes data.

In addition all of the above conditions shall be reported as, at minimum, a common alarm indication via the remote interrogation facility.

5.6 Communications

For integral Outstations: Outstation(s) shall provide both local and remote interrogation facilities, from separate ports.

To prevent unauthorised access to the data in the Metering Equipment a security scheme, as defined below and in Appendix D, shall be incorporated for both local and remote access. Separate security levels shall be provided for the following activities:

- (i) Level 1 Password for:
- Read-only access to the following metering data, which shall be transferable on request during the interrogation process:
- (a) Outstation ID;
 - (b) Demand Values as defined in clause 4.1.2;
 - (c) Cumulative measured quantities as defined in clause 4.1.1;
 - (d) Maximum Demand (MD) for kW/MW or kVA/MVA as appropriate (as defined by the Registrant) per programmable charging period i.e. monthly or statistical review period;
 - (e) Multi-rate cumulative Active Energy as specified by the Registrant;
 - (f) Measurement transformer ratios, where appropriate (see clause 5.3)
 - (g) Measurement transformer error correction factor and/or system loss factor, where this is a constant factor applied to the entire dynamic range of the Meter and the Meter is combined with the display and/or Outstation;
 - (h) Alarm indications; and
 - (i) Outstation time and date.
- (ii) Level 2 Password for:
- (a) Corrections to Outstation time and/or date; and
 - (b) Resetting of the MD
- (iii) Level 3 Password for:
- Programming of:
- (a) The Displays and Facilities as defined in clause 5.4;
 - (b) Measurement transformer ratios, as appropriate (see clause 5.3);
 - (c) Measurement transformer error correction factor and/or system loss factor, where this is a constant factor applied to the entire dynamic range of the Meter and the Meter is combined with the display and/or Outstation; and
 - (d) The Passwords for levels 1, 2 and 3;

In addition it shall be possible to read additional information within the Metering Equipment to enable the programmed information to be confirmed.

- (iv) Level 4 Password for⁵:
 - (a) Calibration of the Metering Equipment;
 - (b) Setting the measurement transformer ratios, where appropriate (see clause 5.3);
 - (c) Setting the measurement transformer error correction and/or system loss factors where this is other than a single factor; and
 - (d) Programming the level 3 Password and the level 4 Password, if appropriate.

In addition to the functions specified for each level it shall be feasible to undertake functions at the preceding level(s). E.g. at level 3 it shall also be possible to carry out the functions specified at levels 1 and 2. This need not apply at level 4 when access is obtained via removing the cover. Different Passwords shall be utilised for each level, which shall only be circulated in accordance with the relevant BSC Procedure.

For separate Outstations: A Password shall be required to read or change any data.

5.6.1 Local Interrogation

An interrogation port shall be provided for each Outstation which preferably shall be an opto port to BS EN 62056-21, and with a serial protocol such as BS EN 62056-21, for the following purposes:-

- (i) Commissioning, maintenance and fault finding;
- (ii) Transfer of metering data and alarms; and
- (iii) Time setting.

5.6.2 Remote Interrogation

Remote interrogation facilities shall be provided with error checking of the communications between the Outstation System and the Settlement Instation.

Interrogation of an Outstation shall be possible using one of the following media:

- (i) Switched telephone networks e.g. PSTN or CTN;
- (ii) Public data networks e.g. PSN;
- (iii) Radio data networks e.g. Paknet or any equivalent;
- (iv) Customer own network;
- (v) Mains signalling / power line carrier;
- (vi) Low power radio;

⁵ These may be facilitated by the breaking of a seal.

- (vii) Satellite; or
- (viii) Cable TV.

In addition any further media may be used as approved by the Panel.

The actual media employed shall be in accordance with the requirements of the CDCA for CVA Metering Systems and the Supplier for SVA Metering Systems.

The data shall be to a format and protocol approved by the Panel in accordance with BSCP601.

5.7 Sealing

All SVA Metering Equipment shall be sealed in accordance with Appendix 8 and 9 of the Meter Operation Code of Practice Agreement⁶.

All CVA Metering Equipment shall be capable of being sealed in accordance with BSCP06.

Superseded

⁶ The Meter Operation Code of Practice Agreement is a voluntary agreement between Public Distribution System Operators and Meter Operator Agents.

6. ASSOCIATED FACILITIES**6.1 Interrogation Unit**

The Operator may interrogate the Outstations using an Interrogation Unit (IU). The Interrogation Unit may be used for programming, commissioning, maintenance/fault finding and when necessary the retrieval of stored metering data. The data retrieved by the Interrogation Unit shall be compatible with the Settlement Instation.

6.2 Additional Features

Additional features may be incorporated within or associated with the Metering Equipment provided but these shall not interfere with or endanger the operation of the Settlement process.

7. ACCESS TO DATA

Access to metering data shall be in accordance with the provisions of the Code and the BSC Procedures referred to therein. Such access must not interfere with or endanger the security of the data or the collection process for Settlement purposes.

Access to stored metering data in Outstations shall also be the right of the Registrant and any party who has the permission of the Registrant.

Superseded

APPENDIX A: DEFINED METERING POINTS

For transfers of electricity between the following parties the Defined Metering Point (DMP) shall be at one of the following locations:-

1. For transfers between a Transmission System operator and a single Licensed Distribution System Operator where no other Party(s) are connected to the busbar, the DMP shall be at the lower voltage side of the supergrid connected transformer.
2. For transfers between a Transmission System operator and a single Licensed Distribution System Operator where other Party(s) are connected to the busbar, the DMP shall be at the circuit connections to that Licensed Distribution System Operator.
3. For transfers between a Transmission System operator and more than one Licensed Distribution System Operator connected to the same busbar, the DMP shall be at the circuit connections of each Licensed Distribution System Operator to such busbar.
4. For transfers between Licensed Distribution System Operators not including a connection to the Transmission System, the DMP shall be at the point of connection of the two Licensed Distribution System Operators.
5. For transfers between a Transmission System operator and:-
 - (i) Generating Plant, the DMP shall be at the high voltage side of the generator transformers and station transformer(s).
 - (ii) An Offshore Power Park Module(s) comprising a single BM Unit, the DMP shall be at the point(s) of connection of the Offshore Power Park Module to the Transmission System. A Party may install Metering Equipment at either:
 - the DMP; or
 - a point or points on the Offshore Platform, other than the DMP. Such point or points shall be the Actual Metering Point for the purposes of this Code of Practice.
6. For transfers between a Licensed Distribution System Operator and Generating Plant, the DMP shall be at the point(s) of connection of the generating station to the Licensed Distribution System Operator.
7. For transfers between a Licensed Distribution System Operator and a Customer, the DMP shall be at the point of connection to the Licensed Distribution System Operator.
8. For transfers between a Transmission System operator and a Customer, the DMP shall be at the point of connection to the Transmission System operator.
9. For transfers between a Transmission System operator and an External System the DMP shall be as follows:-
 - (i) For the EdF link the busbar side of the busbar disconnectors at the Sellindge 400 kV Substation.
 - (ii) For the Moyle Interconnector, the Converter Station side of the L15 circuit breaker on the Coylton feeder at Auchencrosh Substation.

10. For transfers between an Offshore Transmission System (or Offshore Transmission System User Assets) and a Distribution System operated by a Licensed Distribution System Operator, the DMP shall be at the point(s) of connection to that Distribution System operated by a Licensed Distribution System Operator.

Superseded

APPENDIX B: LABELLING OF METERS FOR IMPORT AND EXPORT

1 A standard method of labelling Meters, test blocks, etc is necessary and based on the definitions for Import and Export the required labelling shall be as follows.

2 **ACTIVE ENERGY**

Meters or Meter Registers shall be labelled "Import" or "Export" according to the diagram "Figure 1".

3 **REACTIVE ENERGY FOR METERS REGISTERED IN CMRS**

Within the context of this code the relationship between Active Energy and Reactive Energy can best be established by means of the power factor. The following table gives the relationship:-

Flow of Active Energy	Power Factor	Flow of Reactive Energy
Import	Lagging	Import
Import	Leading	Export
Import	Unity	Zero
Export	Lagging	Export
Export	Leading	Import
Export	Unity	Zero

Meters or Meter Registers for registering Import Reactive Energy should be labelled "Import" and those for registering Export Reactive Energy should be labelled "Export".

4 REACTIVE ENERGY FOR METERS REGISTERED IN SMRS

Within the context of this code the relationship between Active Energy and Reactive Energy can best be established by means of the power factor. The following table gives the relationship:-

Flow of Active Energy	Power Factor	Flow of Reactive Energy	Additional Information
Import	Lagging	Import	Associated with Active Import
Import	Leading	Export	Associated with Active Import
Import	Unity	Zero	n/a
Export	Lagging	Export	Associated with Active Export
Export	Leading	Import	Associated with Active Export
Export	Unity	Zero	n/a

Meters or Meter Registers for registering Import Reactive Energy should be labelled “Import” and those for registering Export Reactive Energy should be labelled “Export” but with additional information for reactive Meters or Registers identifying the Active Meter or Register it is associated with.

FIGURE 1 IMPORT AND EXPORT ACTIVE ENERGY FLOWS CONVENTION

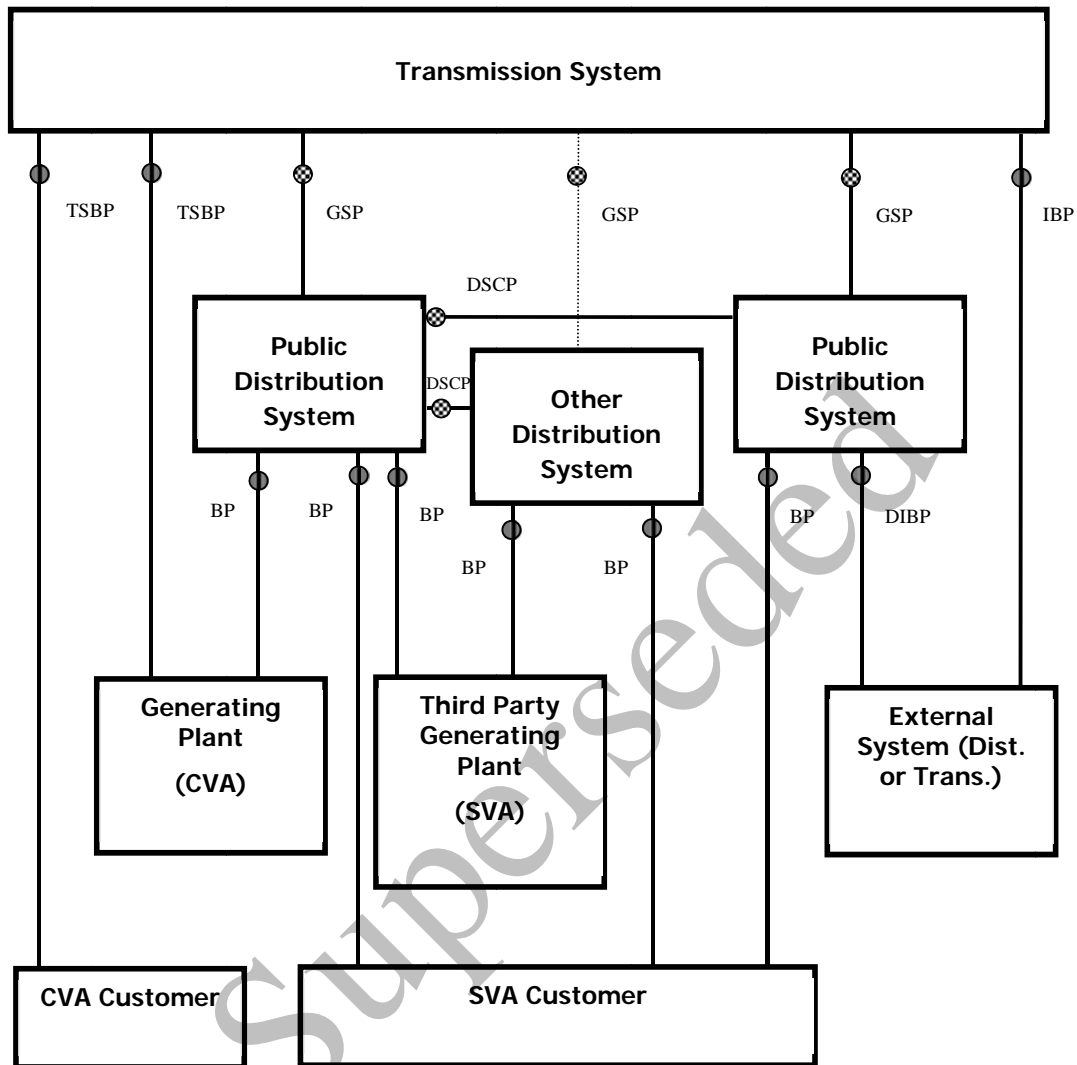
**Key**

● Boundary Point

⊗ System Connection Point

Import ↓

Export ↑

Import / Export Energy Flow Convention for the labelling of Meters

Import metering measures energy flows away from the Transmission System.

Export metering measures energy flows towards the Transmission System.

Energy flows between Distribution Systems is by bilateral agreement.

Key to abbreviations used in Import / Export Diagram

○	Metering Point
BP	Boundary Point
DIBP	Distribution Interconnector Boundary Point
DSCP	Distribution System Connection Point
GSP	Grid Supply Point
IBP	Interconnector Boundary Point
SCP	System Connection Point
TSBP	Transmission System Boundary Point

Superseded

APPENDIX C: FUSING

The following diagrams show typical arrangements for the fusing requirements of this Code of Practice. The diagrams are non-exhaustive and are provided for reference only.

Figure 1: Fusing arrangements for cable runs of less than 30 metres distance between source fusing and local means of isolation^{7 8}.

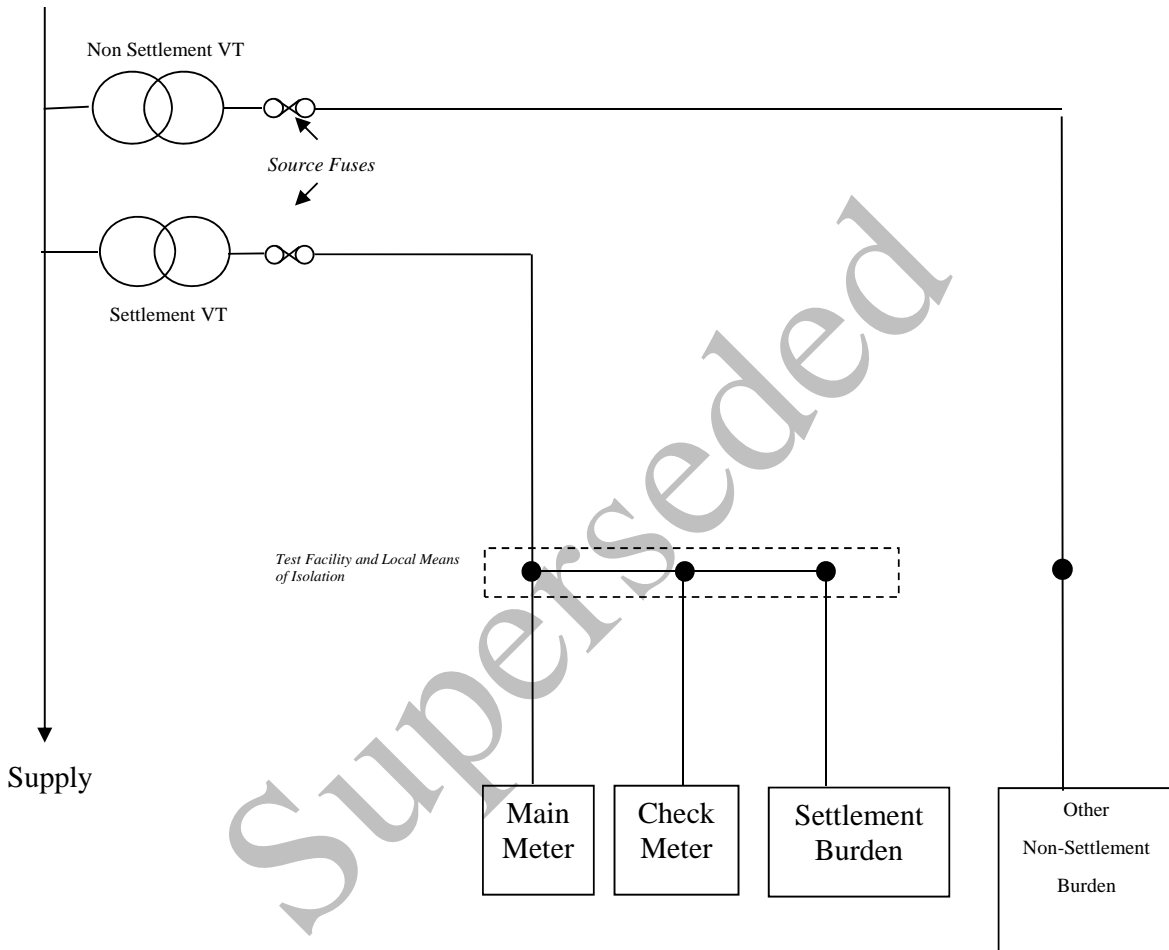

Note:

Source fusing and local means of isolation shall include the use of solid links in the potential return conductor.

The boundary between Meter Operator Equipment and the Transmission/Distribution System Operator is between the local means of isolation and the testing facilities.

⁷ Isolation may be provided by the use of solid links or fuses and may be placed on either side of the test terminal block. Where fuses are to be used, the additional burden shall be accounted for.

⁸ Check Meters and other burden may be supplied via an additional secondary winding of the VT

Figure 2: Fusing arrangements for cable runs of more than 30 metres distance between source fusing and local means of isolation^{9 10}.

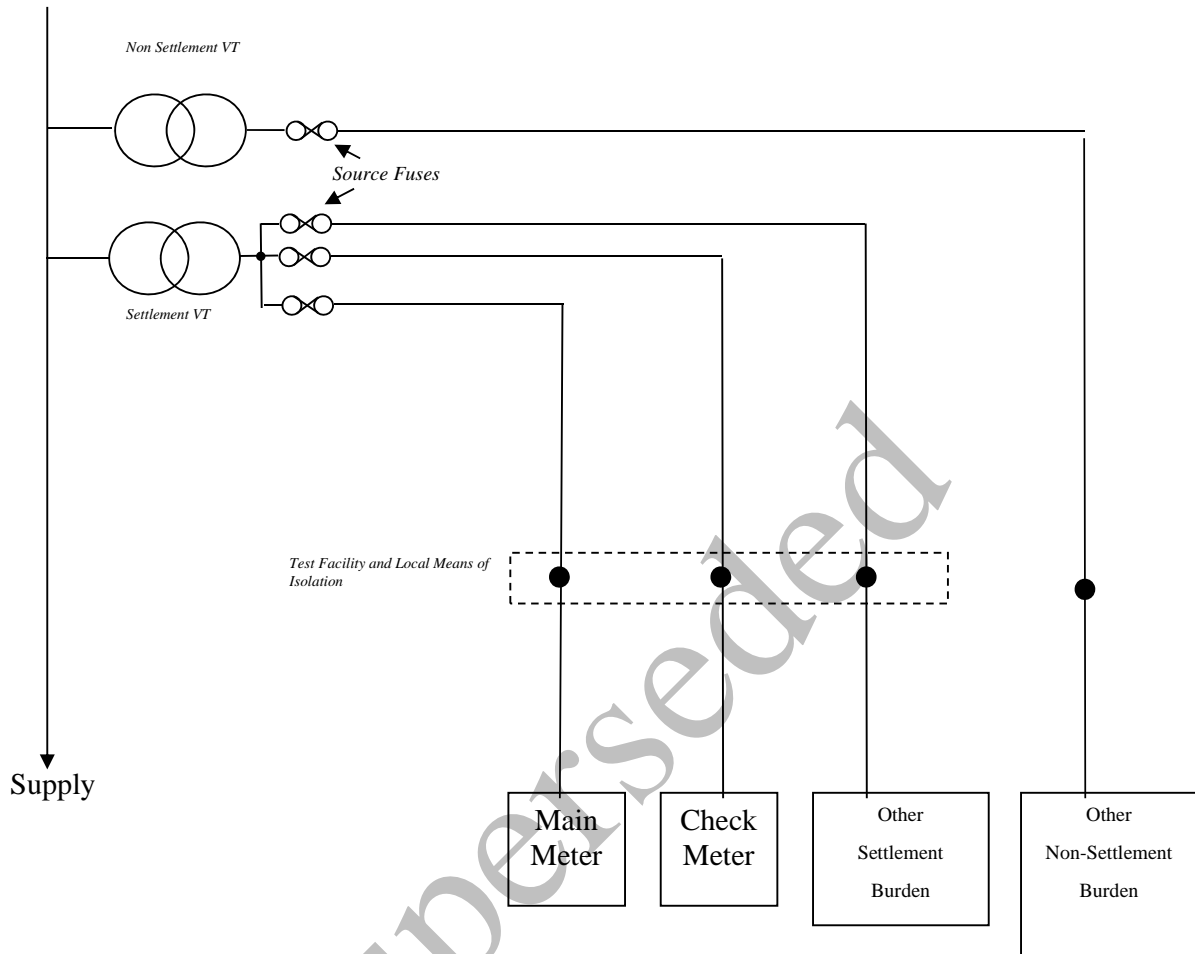

⁹ Local isolation may be provided by the use of solid links or fuses and may be placed on either side of the test terminal block. Where fuses are to be used, the additional burden shall be accounted for.

¹⁰ Check Meters and other burden may be supplied via an additional secondary winding of the VT.

APPENDIX D: PASSWORDS

The Passwords specified in clause 5.6 shall be subject to the following additional requirements:

- (i) The communications protocol employed shall ensure that the Password offered determines the level of access to the data within the Metering Equipment.
- (ii) A counter to log the number of illegal attempts (i.e. Password comparison failures) to access Metering Equipment via the local and remote ports shall be incorporated into the log-on process. This counter shall reset to zero at every hour change (i.e. 0100, 0200, etc).
- (iii) If the counter reaches 7, then access is prohibited at all levels until the counter resets at the next hour change.

Superseded

APPENDIX E: GUIDANCE FOR THE USE OF MULTI CORE METERING CABLES

Multi core cables are predominantly used to provide CT and VT signals to the Meter. However such arrangements may cause additional errors that are not readily apparent to the Metering System designer. This guidance provides information that should be considered when using multi core cables for metering, particularly if used over long cable runs.

Consideration shall be given to the cross sectional area of the conductors of multi core cables:

- (i) In CT circuits the cabling resistance is likely to represent an appreciable component of the CT burden and care should be taken to ensure that the CT overall burden is not exceeded;
- (ii) For the VT circuits, cabling and fuses introduce volt drop errors. Fuses with a low current rating tend to have a relatively high resistance value and are variable from fuse to fuse. Careful selection of fuses, fuse holders and the doubling of cores can be used to mitigate these effects.

The proximity of CT and VT signals in multi-core cables can cause errors due to capacitive coupling from the voltage to the current circuits. The effect of this coupling is more prevalent at low loads and with long cable runs, in particular with 1 amp rated CTs. One possible symptom of this condition is that the Meters may advance under no load conditions (circuit energised but with no load current). This coupling effect may be eliminated by careful allocation of cable core to function, or by running CT and VT signals in separate cables.

APPENDIX F: GUIDANCE FOR THE COMMUNICATION ARRANGEMENTS FOR METERING SYSTEMS LOCATED OFFSHORE AT OFFSHORE POWER PARK MODULES

In this Code of Practice, it is a minimum requirement that a set of Measurement Transformers be provided which are dedicated for Settlement use and may be used for both the main and the check Meter that are required for each measured circuit.

Where one or more Outstations that are not integral with an associated Meter are provided, each Outstation shall store the main and check Meter data for one or more circuits up to a Maximum Aggregated Capacity of 100 MVA. Separate Outstations storing data from a number of different circuits may be cascaded on to one Communication Line.

Metering Systems comprising Meters with integral Outstations need not store data from the associated main or check Meter providing that each Outstation has separate communications.

For Metering Systems located Offshore measuring Offshore Power Park Module export and import, main and check data shall be accessible using either of separate Communication Lines, and a single point of failure in the communication path between an instation and an Outstation shall not prevent access to main and check metering data stored in required Outstations. For Outstations which are not integral with an associated Meter, both main and check Meter data should be stored on duplicate Outstations each having at least one independent Communication Line. Outstations storing data from different circuits may be cascaded on to one Communication Line as if they were parts of one Outstation.

Where shared communication network components are used, for example copper wire or optical fibre and associated connectors, routers and switches with Internet Protocol (IP) addressing of end points, the Registrant should ensure that the requirement for independent communication lines is achieved by the existence of sufficient duplication and redundancy to ensure that two or more independent end to end communication paths exist between the instation and Outstation. The following examples show some possible arrangements for guidance, using an optical fibre cable in which at least two of the fibres are independently allocated to Settlement metering data in order to satisfy the requirement for separate Communication Lines.

Example 1 Meters with integral Outstations using optical fibre communications

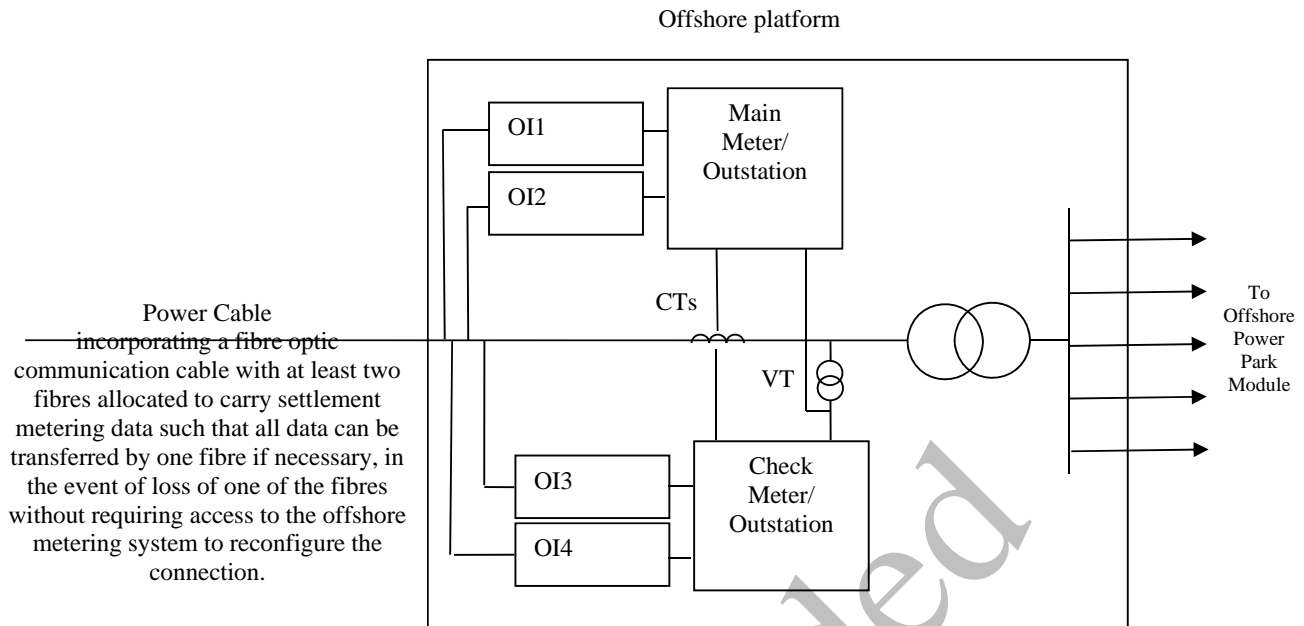

In this example, there is a single power cable connecting the Offshore Power Park Module to the mainland which incorporates a fibre optic communication cable.

The communication cable contains multiple optical fibres and is used amongst other things to provide communications between the Settlement instation and the Outstations which are located on the offshore platform. Sufficient optical fibres should be allocated to the Settlement communications to ensure that main and check data can continue to be collected automatically without requirement for physical access to the Offshore Metering Equipment in the event of failure of any individual allocated fibre.

The Meters have integral Outstations each storing main and check data separately. If each Outstation stored data from both main and check Meters then only two Communication Lines would be necessary (OI1 and OI3 or OI2 and OI4) as the failure of either one would not prevent access to both main and check metering data (as in Example 2). However in this example this is not the case therefore additional Communication Lines are required. Each Meter has two optical interfaces (OI1, OI2 and OI3, OI4) and each has a unique IP address.

There are two Outstations and four Communication Lines.

This example shows a single optical cable being used but would equally apply to multiple cables or any other communications media such as satellite communications or PSTN.

Example 2 Meters with separate Outstations using optical fibre communications

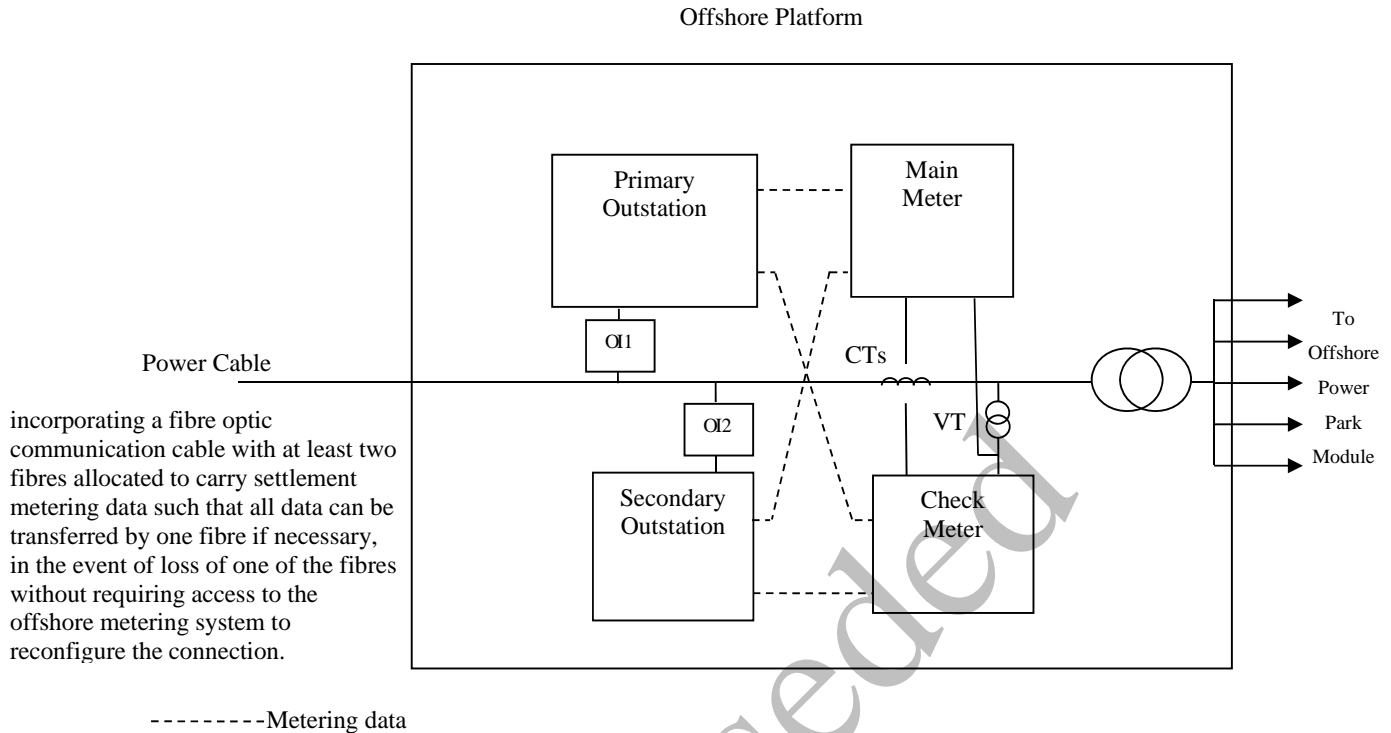

incorporating a fibre optic communication cable with at least two fibres allocated to carry settlement metering data such that all data can be transferred by one fibre if necessary, in the event of loss of one of the fibres without requiring access to the offshore metering system to reconfigure the connection.

In this example, there is a single power cable connecting the Offshore Power Park Module to the mainland which incorporates a fibre optic communication cable.

The communication cable contains multiple optical fibres and is used amongst other things to provide communications between the Settlement Installation and the Outstations which are located on the offshore platform. Sufficient optical fibres should be allocated to the Settlement communications to ensure that main and check data can continue to be collected automatically without requirement for physical access to the Offshore Metering Equipment in the event of failure of any individual allocated fibre.

The Meters transfer readings to both the separate Outstations and each Outstation has one optical interfaces (OI1 and OI2). Each optical interface has a unique IP address.

There are two Outstations and two Communication Lines.

This example shows a single optical cable being used but would equally apply to multiple cables or any other communications media such as satellite communications or PSTN.