

**CODE OF PRACTICE ONE**

**CODE OF PRACTICE FOR THE METERING OF  
CIRCUITS WITH A RATED CAPACITY  
EXCEEDING 100MVA FOR SETTLEMENT**

**Issue 2**

**Version 3.0**

**DATE:**

---

**Code of Practice One**

**CODE OF PRACTICE FOR THE METERING OF CIRCUITS WITH A RATED CAPACITY EXCEEDING 100MVA FOR SETTLEMENT PURPOSES.**

1. Reference is made to the Balancing and Settlement Code for the Electricity Industry in Great Britain, and in particular, to the definitions of “Code of Practice” in Annex X-1 thereof.
2. This Code of Practice shall apply to Metering Systems comprising Metering Equipment that are subject to the requirements of Section L of the Balancing and Settlement Code.
3. This Code of Practice has been approved by the Panel.

For and on behalf of the Panel.

**Intellectual Property Rights and Copyright** - This document contains materials the copyright and other intellectual property rights in which are vested in ELEXON Limited or which appear with the consent of the copyright owner. These materials are made available for you to review and to copy for the purposes of your establishment or operation of or participation in electricity trading arrangements under the Balancing and Settlement Code ("BSC"). All other commercial use is prohibited. Unless you are a person having such an interest in electricity trading under the BSC you are not permitted to view, download, modify, copy, distribute, transmit, store, reproduce or otherwise use, publish, licence, transfer, sell or create derivative works (in whatever format) from this document or any information obtained from this document otherwise than for personal academic or other non-commercial purposes. All copyright and other proprietary notices contained in the original material must be retained on any copy that you make. All other rights of the copyright owner not expressly dealt with above are reserved.

**Disclaimer** - No representation, warranty or guarantee is made that the information provided is accurate, current or complete. Whilst care is taken in the collection and provision of this information, ELEXON Limited will not be liable for any errors, omissions, misstatements or mistakes in any information or damages resulting from the use of this information or any decision made or action taken in reliance on this information.

### AMENDMENT RECORD

ISSUE	DATE	VERSION	CHANGES	AUTHOR	APPROVED
Draft	18/3/93	0.10	Recommended to PEC	MSC	
1	15/4/93	1.00	Endorsed by PEC	CoP WG	
1	Code Effective Date <sup>1</sup>	1.00	Re-badging of Code of Practice One for the implementation of the Balancing and Settlement Code	BSCCo	Panel 16/11/00 (Paper 07/003)
1	BETTA Effective Date	2.0	BETTA 6.3 Rebadging changes for the CVA Feb 05 Release	BSCCo	
2	23/02/06	3.0	CP1051 changes for the February 06 Release	BSCCo	ISG/55/002

<sup>1</sup> “Code Effective Date” means the date of the Framework Agreement.

---

**CODE OF PRACTICE FOR THE METERING OF CIRCUITS WITH A  
RATED CAPACITY EXCEEDING 100MVA FOR SETTLEMENT  
PURPOSES.**

<b>CONTENTS</b>	<b>Page number</b>
FOREWORD	6
1. SCOPE	7
2. REFERENCES	8
3. DEFINITIONS AND INTERPRETATIONS	9
4. MEASUREMENT CRITERIA	13
4.1 Measured Quantities and Demand Values	13
4.1.1 Measured Quantities	13
4.1.2 Demand Values	13
4.2 Accuracy Requirements	14
4.2.1 Overall Accuracy	14
4.2.2 Compensation for Measurement Transformer Error	15
4.2.3 Compensation for Power Transformer and Line Losses	15
5. METERING EQUIPMENT CRITERIA	16
5.1 Measurement Transformers	16
5.1.1 Current Transformers	16
5.1.2 Voltage Transformers	17
5.1.3 Monitoring of Voltage Transformers	17
5.1.4 Measurement Transformers Installed on Existing Circuits	18
5.2 Testing Facilities	18
5.3 Meters	19
5.4 Displays and Facilities for Registrant Information	20
5.4.1 Displays	20
5.4.2 Facilities	21
5.5 Outstation	22
5.5.1 Data Storage	22
5.5.2 Time Keeping	23
5.5.3 Monitoring Facilities	24

---

<b>CONTENTS</b>		<b>Page number</b>
5.6	Communication	24
5.6.1	Local Interrogation	26
5.6.2	Remote Interrogation	26
5.7	Sealing	27
6.	ASSOCIATED FACILITIES	28
6.1	Interrogation Unit	28
6.2	Additional Features	28
7.	ACCESS TO DATA	28
APPENDIX A	Defined Metering Points	29
APPENDIX B	Labelling of Meters for Import and Export	31
APPENDIX C	Fusing	34
APPENDIX D	Passwords	35
APPENDIX E	Guidance for the Use of Multi Core Metering Cables	36

## FOREWORD

This Code of Practice defines the minimum requirements for the Metering Equipment required for the measurement and recording of electricity transfers at Defined Metering Points where the rated circuit capacity exceeds 100MVA.

For the purpose of this Code of Practice the rated circuit capacity in MVA shall be determined by the lowest rated primary plant (eg transformer rating, line rating, etc) of the circuit. The Metering Equipment provision and accuracy requirements shall anticipate any future up-rating consistent with the installed primary plant. The primary plant maximum continuous ratings shall be used in this assessment.

For the purpose of this Code of Practice, the use of summation current transformers shall not be permitted. The use of interposing current transformers is permitted providing the overall Metering System accuracy is maintained.

Where a material change to a Metering System takes place, then this Metering System must be modified to comply with the most up to date version of this Code of Practice. Changes to a Metering System are considered to be material where they constitute a change to:

- i. Switchgear containing measurement transformers; and/or
- ii. The primary plant associated with the Metering System i.e. measurement transformers.

Where a Metering Dispensation applies and where the Actual Metering Point is not at the Defined Metering Point, a material change affecting the Defined Metering Point may not affect the Metering System at the Actual Metering Point.

BSCCo shall retain copies of, inter alia, this Code of Practice together with copies of all documents referred to in it, in accordance with the provisions of the Balancing and Settlement Code ("the Code").

## 1. SCOPE

This Code of Practice states the practices that shall be employed, and the facilities that shall be provided for the measurement and recording of the quantities required for Settlement purposes on each circuit where the rated capacity exceeds 100MVA.

It derives force from the Code, and in particular the metering provisions (Section L), to which reference should be made. It should also be read in conjunction with any relevant BSC Procedures.

This Code of Practice does not contain the calibration, testing and commissioning requirements for Metering Equipment used for Settlement purposes. These requirements are detailed in Code of Practice Four – “Code of Practice for Calibration, Testing and Commissioning Requirements for Metering Equipment for Settlement Purposes”.

Metering Dispensations from the requirements of this Code of Practice may be sought in accordance with the Code and BSC Procedure BSCP32.

In the event of an inconsistency between the provisions of this Code of Practice and the Code, the provisions of the Code shall prevail.

## 2. REFERENCES

The following documents are referred to in the text:-

BS EN 62053-22	Electricity metering equipment (a.c.). Particular requirements. Static meters for active energy (classes 0.2 S and 0.5 S)
BS EN 62053-23	Electricity metering equipment (a.c.). Particular requirements. Static meters for reactive energy (classes 2 and 3)
BS EN 62056-21	Electricity Metering. Data exchange for meter reading, tariff and load control. Direct local data exchange
BS EN 60044-3	Instrument transformers. Combined transformers
IEC 60044-1	Instrument transformers. Current transformers
IEC 60044-2	Instrument transformers. Inductive voltage transformers
Balancing and Settlement Code	Section X; Annex X-1 and Section L and BSC Procedures
Code of Practice Four	Code of Practice for Calibration, Testing and Commissioning Requirements for Metering Equipment for Settlement Purposes
BSC Procedures	BSCP06, BSCP32, BSCP601
Electricity Act 1989	Schedule 7 as amended by Schedule 1 to the Competition and Services (Utilities) Act 1992.



### 3. DEFINITIONS AND INTERPRETATIONS

Save as otherwise expressly provided herein, words and expressions used in this Code of Practice shall have the meanings attributed to them in the Code.

The following definitions, which also apply, supplement or complement those in the Code and are included for the purpose of clarification.

#### 3.1 Active Energy

Active Energy means the electrical energy produced, flowing or supplied by an electrical circuit during a time interval, and being the integral with respect to time of the instantaneous Active Power, measured in units of watt-hours or standard multiples thereof.

#### 3.2 Active Power

Active Power means the product of voltage and the in-phase component of alternating current measured in units of watts and standard multiples thereof, that is:-

$$\begin{aligned} 1,000 \text{ Watts} &= 1 \text{ kW} \\ 1,000 \text{ kW} &= 1 \text{ MW} \end{aligned}$$

#### 3.3 Actual Metering Point

Actual Metering Point means the physical location at which electricity is metered.

#### 3.4 Apparent Energy

Apparent Energy means the integral with respect to time of the Apparent Power.

#### 3.5 Apparent Power

Apparent Power means the product of voltage and current measured in units of voltamperes and standard multiples thereof, that is:-

$$\begin{aligned} 1,000 \text{ VA} &= 1 \text{ kVA} \\ 1,000 \text{ kVA} &= 1 \text{ MVA} \end{aligned}$$

#### 3.6 Central Data Collection Agent (CDCA)

Central Data Collection Agent means the BSC Agent for Central Data Collection in accordance with Section E of the Code.

#### 3.7 CTN

CTN means the Electricity Supply Industry (ESI) corporate telephone network.

#### 3.8 CVA

---

CVA means Central Volume Allocation

3.9 CVA Customer

CVA Customer means any customer, receiving electricity directly from the Transmission System, irrespective of from whom it is supplied.

3.10 Defined Metering Point

Defined Metering Point means the physical location at which the overall accuracy requirement as stated in this Code of Practice are to be met. The Defined Metering Points are identified in Appendix A and relate to Boundary Points and System Connection Points.

3.11 Demand Period

Demand Period means the period over which Active Energy, Reactive Energy or Apparent Energy are integrated to produce Demand Values. For Settlement purposes, each Demand Period shall be of 30 minutes duration, one of which shall finish at 24:00 hours.

3.12 Demand Values

Demand Values means, expressed in MW, Mvar or MVA, twice the value of MWh, Mvarh or MVAh recorded during any Demand Period<sup>2</sup>. The Demand Values are half hour demands and these are identified by the time of the end of the Demand Period.

3.13 electricity

“electricity” means Active Energy and Reactive Energy.

3.14 Export

Export means, for the purposes of this Code of Practice, an electricity flow as indicated in Figure 1 of Appendix B.

3.15 Import

Import means, for the purposes of this Code of Practice, an electricity flow as indicated in Figure 1 of Appendix B.

3.16 Interrogation Unit

Interrogation Unit means a Hand Held Unit “HHU” (also known as Local Interrogation Unit “LIU”) or portable computer which can enter Metering Equipment

---

<sup>2</sup> Please note that these Demand Values are for use with CVA Metering Systems. SVA Metering Systems shall use units a factor of 10<sup>3</sup> smaller than CVA e.g. kW rather than MW.

parameters and extract information from the Metering Equipment and store this for later retrieval.

3.17 Meter

Meter means a device for measuring Active Energy and/or Reactive Energy.

3.18 Metering Equipment

Metering Equipment means Meters, measurement transformers (voltage, current and combination units), metering protection equipment including alarms, circuitry, associated Communications Equipment and Outstation and wiring.

3.19 Meter Register

Meter Register means a device, normally associated with a Meter, from which it is possible to obtain a reading of the amount of Active Energy, or the amount of Reactive Energy that has been supplied by a circuit.

3.20 Outstation

Outstation means equipment which receives and stores data from a Meter(s) for the purpose, inter-alia, of transfer of that metering data to the Central Data Collection Agent (CDCA) or a Data Collector as the case may be and which may perform some processing before such transfer and may be in one or more separate units or may be integral with the Meter.

3.21 Outstation System

Outstation System means one or more Outstations linked to a single communication line.

3.22 PSTN

PSTN means the public switched telephone network.

3.23 Password

For Meters with integral Outstations: 'Password' means a string of characters of length no less than six and no more than twelve characters, where each character is a case insensitive alpha character (A to Z) or a digit (0 to 9) or the underscore character (\_). Passwords must have a minimum of 2,000,000 combinations, for example six characters if composed of any alphanumeric characters or eight characters if composed only of hexadecimal characters (0 to F).

For separate Outstations: a Password may be described as above for integral Outstations or a single password of any format<sup>3</sup>.

### 3.24 Rated Measuring Current

Rated Measuring Current means the rated primary current of the current transformers in primary plant used for the purposes of measurement.

### 3.25 Reactive Energy

Reactive Energy means the integral with respect to time of the Reactive Power.

### 3.26 Reactive Power

Reactive Power means the product of voltage and current and the sine of the phase angle between them, measured in units of voltamperes reactive and standard multiples thereof;

### 3.27 Registrant

means, in relation to a Metering System, the person for the time being registered in CMRS or (as the case may be) SMRS in respect of that Metering System pursuant to Section K of the Balancing and Settlement Code.

### 3.28 Settlement Instation

Settlement Instation means a computer based system which collects or receives data on a routine basis from selected Outstation by the Central Data Collection Agent or (as the case may be) a relevant Data Collector.

### 3.29 SVA

SVA means Supplier Volume Allocation.

### 3.30 SVA Customer

means a person to whom electrical power is provided, whether or not that person is the provider of that electrical power; and where that electrical power is measured by a SVA Metering System.

---

<sup>3</sup> Meters separate from their Outstation and capable of external communications should have the same password requirements as for separate Outstations.

## 4. MEASUREMENT CRITERIA

### 4.1 Measured Quantities and Demand Values

The following measured quantities and Demand Values are for use with CVA Metering Systems. SVA Metering Systems shall use units a factor of  $10^3$  smaller than CVA e.g. kWh rather than MWh.

#### 4.1.1 Measured Quantities

For each separate circuit the following energy measurements are required for Settlement purposes:-

- (i) Import MWh
- (ii) Export MWh
- (iii) Import Mvarh
- (iv) Export Mvarh

#### 4.1.2 Demand Values

For each Demand Period for each circuit the following Demand Values shall be provided:-

- (i) Import MW
- (ii) Export MW
- (iii) Import Mvar
- (iv) Export Mvar

4.2 Accuracy Requirements4.2.1 Overall Accuracy

The overall accuracy of the energy measurements at or referred to the Defined Metering Point shall at all times be within the limits of error as shown:-

## (i) Active Energy

CONDITION	LIMIT OF ERRORS AT STATED SYSTEM POWER FACTOR	
	Power Factor	Limits of Error
Current expressed as a percentage of Rated Measuring Current		
120% to 10% inclusive	1	$\pm 0.5\%$
Below 10% to 5%	1	$\pm 0.7\%$
Below 5% to 1%	1	$\pm 1.5\%$
120% to 10% inclusive	0.5 lag and 0.8 lead	$\pm 1.0\%$

## (ii) Reactive Energy

CONDITION	LIMIT OF ERRORS AT STATED SYSTEM POWER FACTOR	
	Power Factor	Limits of Error
Current expressed as a percentage of Rated Measuring Current		
120% to 10% inclusive	Zero	$\pm 4.0\%$
120% to 20% inclusive	0.866 lag and 0.866 lead	$\pm 5.0\%$

These limits of error for both (i) and (ii) above shall apply at the Reference Conditions defined in the appropriate Meter specification.

Evidence to verify that these overall accuracy requirements are met shall be available for inspection by the Panel or Technical Assurance Agent.

#### 4.2.2 Compensation for Measurement Transformer Error

To achieve the overall accuracy requirements it may be necessary to compensate Meters for the error of the measurement transformers and the associated leads to the Meters. Values of the compensation shall be recorded and evidence to justify the compensation criteria, including wherever possible test certificates, shall be available for inspection by the Panel or Technical Assurance Agent.

#### 4.2.3 Compensation for Power Transformer and Line Losses

Where the Actual Metering Point and the Defined Metering Point do not coincide then a Metering Dispensation shall be applied for and, where necessary, compensation for power transformer and/or line losses shall be provided to meet the overall accuracy at the Defined Metering Point.

The compensation may be achieved either within the Metering Equipment or within the Data Collector's software.

Where compensation is applied the values used shall be recorded and supporting evidence to justify the compensation criteria shall be available for inspection by the Panel or Technical Assurance Agent.

## 5. METERING EQUIPMENT CRITERIA

Although for clarity this Code of Practice identifies separate items of equipment, nothing in it prevents such items being combined to perform the same task provided the requirements of this Code of Practice are met.

Metering Equipment other than outdoor measurement transformers, shall be accommodated in a clean and dry environment.

### 5.1 Measurement Transformers

All measurement transformers shall be of a wound construction.

For each circuit current transformers (CT) and voltage transformers (VT) shall meet the requirements set out in clauses 5.1.1 and 5.1.2.

Additionally, where a combined unit measurement transformer (VT & CT) is provided the 'Tests for Accuracy' as covered in clause 8 of BS EN 60044-3 covering mutual influence effects shall be met.

For Metering Systems that represent low burdens on measurement transformers, consideration shall be given as to whether that operating burden is within the operating range of the measurement transformers. In such cases it may be necessary to add additional burden.

Guidance for the use of multi core cables is provided in Appendix E.

#### 5.1.1 Current Transformers

Two sets of current transformers in accordance with IEC 60044-1 and with a minimum standard of accuracy class 0.2S (irrespective of the secondary current rating of the current transformers) shall be provided.

The current transformers supplying the main Meters shall be dedicated to that purpose.

The current transformers supplying the check Meters may be used for other purposes provided the overall accuracy requirements in paragraph 4.2.1 are met and evidence of the value of the additional burden is available for inspection by the Panel or Technical Assurance Agent. The additional burden shall not be modified without prior notification to the Panel, and the evidence of the value of the modified additional burden shall be available for inspection by the Panel or Technical Assurance Agent.



CT test certificates showing errors at the overall working burden or at burdens which enable the working burden errors to be calculated shall be available for inspection by the Panel or Technical Assurance Agent.

The total burden on each current transformer shall not exceed the rated burden of such CT.

#### 5.1.2 Voltage Transformers

Two voltage transformers or one voltage transformer with two or more secondary winding sets in accordance with IEC 60044-2 and with a minimum standard of accuracy class 0.2 shall be provided.

The VT secondary winding supplying the main Meters shall be dedicated to that purpose.

The VT secondary winding supplying the check Meters may be used for other purposes provided the overall accuracy requirements in clause 4.2.1 are met and evidence of the value of the additional burden is available for inspection by the Panel or Technical Assurance Agent. The additional burden shall not be modified without prior notification to the Panel, and evidence of the value of the modified additional burden shall be available for inspection by the Panel or Technical Assurance Agent.

A VT test certificate(s) showing errors at the overall working burden(s) or at burdens which enable the working burden errors to be calculated shall be available for inspection by the Panel or Technical Assurance Agent.

The total burden on each secondary winding of a VT shall not exceed the rated burden of such secondary winding.

Separately fused VT supplies shall be provided for each of the following:-

- (a) the main Meter
- (b) the check Meter
- (c) any additional burden

Such fuses shall be located as close as practicable to the VT.

#### 5.1.3 Monitoring of Voltage Transformers

Where a common mode fault, such as a VT fuse failure, could cause incorrect voltages on both the main and check Meters, Meters combining integral

Outstations shall provide for the data to be identified with an alarm indicating phase failure.

For separate Outstations, an alarm may be used which shall incorporate a time-delay feature so as to avoid spurious operation. This alarm shall provide notification of a phase failure by the next Working Day at a point which is normally manned.

A spare channel on the Outstation or any other available means may be used to transmit the alarm.

#### 5.1.4 Measurement Transformers Installed on Existing Circuits

Where circuits, other than those newly installed, are to be metered to this Code of Practice and where the installed measurement transformers do not comply fully with clauses 5.1.1 & 5.1.2, then such measurement transformers may be used providing the requirements in clauses 4.2.1 and 5.1.3 are met.

#### 5.2 Testing Facilities

Separate test terminal blocks or equivalent facilities shall be provided for the main Meters and for the check Meters of each circuit. The test facilities shall be nearby the Meters involved.

### 5.3 Meters

The quantities defined in clause 4.1.1 shall be measured by both main and check Meters.

Active Energy Meters shall meet the requirements of BS EN 62053-22 Class 0.2S.

All Meters shall be set to the actual primary and secondary ratings of the measurement transformers and the actual ratios displayed on the display or nameplate of the Meter.

Active Energy Meters shall be configured such that the number of measuring elements is equal to or one less than the number of primary system conductors. These include the neutral conductor, and/or the earth conductor where system configurations enable the flow of zero sequence energy.

Reactive Energy Meters shall meet the Class 2.0 requirements of BS EN 62053-23.

All Meters shall be labelled or otherwise be readily identifiable in accordance with Appendix B.

All Meters shall include a non-volatile Meter Register of cumulative energy for each measured quantity. The Meter Register(s) shall not roll-over more than once within the normal Meter reading cycle.

Meters which provide data to separate Outstations shall for this purpose provide two outputs per measured quantity.

For Meters using electronic displays due account shall be taken of the obligations of the Central Data Collection Agent (CDCA) or other Data Collectors to obtain Meter readings.

Fusing shall be placed as close as practicable to the VT. In addition, means of isolation shall be provided locally for each Meter, any additional burden, and their associated test facilities in accordance with Appendix C.

## 5.4 Displays and Facilities for Registrant Information

### 5.4.1 Displays

The Metering Equipment shall display the following primary information (not necessarily simultaneously):

i. Mandatory Displays:

- a) Measured quantities as per clause 4.1.1;
- b) Current time (“UTC”) and date;
- c) Measurement transformer ratios (see clause 5.3); and
- d) Any compensation factor which has been applied for measurement transformer errors and/or system losses, where this is a constant factor<sup>4</sup> applied at security level 3 (i.e. where the Meter is combined with the display and/or Outstation).

Metering Equipment shall be capable of enabling the display of the following, as specified by the Registrant:

ii. Display capabilities:

- a) Maximum Demand (MD) for kW or MW as appropriate per programmable charging period i.e. monthly or statistical review period;
- b) Maximum Demand (MD) for kVA or MVA as appropriate per programmable charging period i.e. monthly or statistical review period;
- c) Twice the kWh advance or MWh advance as appropriate since the commencement of a current Demand Period (i.e. kW or MW rising demand);
- d) Cumulative MD;
- e) Number of MD resets; and

---

<sup>4</sup> N.B. This excludes cases where a dynamic range of compensation factors have been applied.

- f) Multi-rate display sequence as specified by the Registrant with a minimum of 8 rates selectable over the calendar year.

MD shall be resettable at midnight of the last day of the charging period and for part chargeable period demands. If a manual reset button is provided then this shall be sealable.

#### 5.4.2 Facilities

The Metering Equipment shall be capable of providing the following information locally to the Customer or Registrant configured to their requirements taking account of the measured quantities (see clause 4.1.1)<sup>5</sup>:

- (i) For active energy in MWh or kWh as appropriate (Import and Export), reactive energy in Mvarh or kVARh as appropriate (Import and Export) – if volt-free contacts are used, then these should use a pulse rate at full load of at least 1000 per Settlement Period with a nominal duration of 80ms per pulse; and
- (ii) A 30 minute reset pulse, and if volt-free contacts are used then this pulse should be within a tolerance of  $\pm 0.1\%$  of the Demand Period from the volt-free contacts with a minimum duration of 80ms.

---

<sup>5</sup> The requirements may be jointly met by the main and check Meters.

## 5.5 Outstation

Duplicate Outstation Systems shall be provided which can be interrogated by Settlement Instations using independent communication lines.

Where separate Outstations are provided these shall each store main and check Meter data for one or more circuits and where practicable shall be configured identically. Separate Outstations storing data from different circuits may be cascaded on to one communication line.

Metering Systems comprising Meters with integral Outstations need not store data from the associated main or check Meter providing that each Outstation has separate communications.

The Outstation data shall be to a format and protocol approved by the Panel in accordance with BSCP601.

The Outstation shall have the ability to allow the metering data to be read by instations other than the Settlement Instation provided the requirements of Section 7 of this Code of Practice are satisfied.

Facilities shall be provided to select a relevant demand period from one of the following values:-

30, 20, 15, 10 and 5 minutes with in each case one demand period ending on the hour.

Normally metering data will be collected by the Settlement Instations by a daily interrogation, but repeat collections of metering data shall be possible throughout the Outstation data storage period.

Outstations shall be fitted with an auxiliary terminal that provides for the Outstation's energisation for remote interrogation purposes. The supply to the auxiliary terminal shall be free of switches and secure, and may be provided from the measurement VT as long as it is separate from the potential measurement circuits.

Where a separate modem associated with the Outstation System is used, then it shall be provided with a secure supply separately fused. Alternatively, line or battery powered modem types may be used.

The Outstations shall provide an alarm output signal at a manned point in the event of a supply failure.

### 5.5.1 Data storage

Data storage facilities for metering data shall be provided as follows:-

- (i) a storage capacity of 48 periods per day for a minimum of 10 days for all Demand Values
- (ii) the stored Demand values shall be integer values of kW/MW or kvar/Mvar as appropriate, or pulse counts, and have a resolution of better than  $\pm 0.1\%$  (at full load);
- (iii) the accuracy of the energy values derived from Demand Values shall be within  $\pm 0.1\%$  (at full load) of the amount of energy measured by the associated Meter;
- (iv) the value of any energy measured in a Demand Period but not stored in that Demand Period shall be carried forward to the next Demand Period;
- (v) where a separate Outstation is used, cumulative register values shall be provided in the Outstation which can be set to match and increment with the Meter Registers;
- (vi) in the event of an Outstation supply failure, the Outstation shall protect all data stored up to the time of the failure, and maintain the time accuracy in accordance with clause 5.5.2;
- (vii) partial Demand Values, those in which an Outstation supply failure and/or restoration occurs, and zero Demand Values associated with an Outstation supply failure, shall be marked so that the Settlement Instation can identify them;
- (viii) to cater for continuous supply failures, the clock, calendar and all data shall be supported for a period of 10 days without an external supply connected;
- (ix) any “read” operation shall not delete or alter any stored metered data; and
- (x) an Outstation shall provide any portion of the data stored upon request by an Instation.

#### 5.5.2 Time Keeping

- (i) The Outstation time shall be set to the Universal Time Clock (UTC) also known as Greenwich Mean Time (GMT). No switching between UTC and British Summer Time (BST) shall occur.
- (ii) Time synchronisation of the Outstation shall only be performed by communication with the Settlement Instation.

(iii) The overall limits of error for the time keeping allowing for a failure to communicate with the Outstation for an extended period of 10 days shall be:-

- a) the completion of each Demand Period shall be at a time which is within  $\pm 10$  seconds of UTC; and
- b) the duration of each Demand period shall be within  $\pm 0.1\%$ , except where time synchronisation has occurred in a Demand Period.

### 5.5.3 Monitoring Facilities

Monitoring facilities shall be provided for each of the following conditions and shall be reported, tagged wherever possible to the relevant Demand Period(s), via the local interrogation facility:-

- (i) error in Outstation functionality;
- (ii) battery monitoring (where battery fitted); and
- (iii) interrogation port access which changes data.

In addition all of the above conditions shall be reported as, at minimum, a common alarm indication via the remote interrogation facility.

## 5.6 Communications

For integral Outstations: Outstation(s) shall accommodate both local and remote interrogation facilities, from separate ports.

To prevent unauthorised access to the data in the Metering Equipment a security scheme, as defined below and in Appendix D, shall be incorporated for both local and remote access. Separate security levels shall be provided for the following activities:

- i. Level 1 Password for:

Read-only access to the following metering data, which shall be transferrable on request during the interrogation process:

- a) Outstation ID;
- b) Demand Values as defined in clause 4.1.2;
- c) Cumulative measured quantities as defined in clause 4.1.1;



- 
- d) Maximum Demand (MD) for kW/MW or kVA/MVA as appropriate per programmable charging period i.e. monthly or statistical review period;
  - e) Multi-rate cumulative Active Energy as specified by the Registrant;
  - f) Measurement transformer ratios, where appropriate (see clause 5.3);
  - g) Measurement transformer error correction factor and/or system loss factor where this is a constant factor applied to the entire dynamic range of the Meter and the Meter is combined with the display and/or Outstation;
  - h) Alarm indications; and
  - i) Outstation time and date.
- ii. Level 2 Password for:
- a) Corrections to the time and/or date; and
  - b) Resetting of the MD.
- iii. Level 3 Password for:
- Programming of:
- a) Displays and facilities as defined in clause 5.4;
  - b) Measurement transformer ratios, as appropriate (see clause 5.3);
  - c) Measurement transformer error correction and/or system loss factor where this is a constant factor applied to the entire dynamic range of the Meter and the Meter is combined with the display and/or Outstation; and
  - d) Passwords for levels 1, 2 and 3.

In addition it shall be possible to read additional information within the Metering Equipment to enable the programmed information to be confirmed.

- iv. Level 4 Password for<sup>6</sup>:
  - a) Calibration of the Metering Equipment;
  - b) Setting the measurement transformer ratios, where appropriate (see clause 5.3);
  - c) Setting the transformer error correction and/or system loss factors where this is other than a single factor; and
  - d) Programming the level 3 Password and the level 4 Password if appropriate.

In addition to the functions specified for each level it shall be feasible to undertake the functions at the preceding level(s). E.g. at level 3 it shall also be possible to carry out the functions specified at levels 1 and 2. This need not apply at level 4 when access is obtained via removing the cover. Different Passwords shall be utilised for each level, which shall only be circulated in accordance with the relevant BSC Procedure.

For separate Outstations: A Password shall be required to read or change any data.

#### 5.6.1 Local Interrogation

An interrogation port shall be provided for each Outstation which preferably shall be an opto port to BS EN 62056-21, and with a serial protocol such as BS EN 62056-21, for the following purposes:-

- (i) Commissioning, maintenance and fault finding;
- (ii) Transfer of metering data and alarms; and
- (iii) Time setting.

#### 5.6.2 Remote Interrogation

Remote interrogation shall be provided with error checking of the communications between the Outstation System and the Settlement Instation.

Interrogation of an Outstation shall be possible using one of the following media:-

- (i) Switched telephone networks e.g. PSTN or CTN;

---

<sup>6</sup> These may be facilitated by the breaking of a seal.

- (ii) Public data networks e.g. PSN;
- (iii) Radio data networks e.g. Paknet or any equivalent;
- (iv) Customer own network;
- (v) Mains signalling / power line carrier;
- (vi) Low power radio;
- (vii) Satellite; or
- (viii) Cable TV.

In addition any further media may be used as approved by the Panel.

The actual media employed shall be in accordance with the requirements of the CDCA for CVA Metering Systems and the Supplier for SVA Metering Systems.

The data shall be to a format and protocol approved by the Panel in accordance with BSC Procedure 601.

#### 5.7 Sealing

All Metering Equipment shall be capable of being sealed in accordance with BSC Procedure BSCP06.

## 6. ASSOCIATED FACILITIES

### 6.1 Interrogation Unit

The Operator may interrogate the Outstations using an Interrogation Unit (IU). The Interrogation Unit may be used for commissioning, maintenance/fault finding and when necessary the retrieval of stored metering data. The data retrieved by the Interrogation Unit shall be compatible with the Settlement Instation.

### 6.2 Additional Features

Additional features may be incorporated within or associated with the Metering Equipment provided but these shall not interfere with or endanger the operation of the Settlement process.

## 7. ACCESS TO DATA

Access to metering data shall be in accordance with the provisions of the Code and the BSC Procedures referred to therein. Such access must not interfere with or endanger the security of the data or the collection process for Settlement purposes.

Access to stored metering data in Outstations shall also be the right of the Registrant and any party who has the permission of the Registrant.

---

**APPENDIX A DEFINED METERING POINTS**

For transfers of electricity between the following parties the Defined Metering Point (DMP) shall be at one of the following locations:-

1. For transfers between a Transmission System operator and a single Licensed Distribution System Operator where no other Party(s) are connected to the busbar, the DMP shall be at the lower voltage side of the supergrid connected transformer.
2. For transfers between a Transmission System operator and a single Licensed Distribution System Operator where other Party(s) are connected to the busbar, the DMP shall be at the circuit connections to that Licensed Distribution System Operator.
3. For transfers between a Transmission System operator and more than one Licensed Distribution System Operator connected to the same busbar, the DMP shall be at the circuit connections of each Licensed Distribution System Operator to such busbar.
4. For transfers between Licensed Distribution System Operators not including a connection to a Transmission System, the DMP shall be at the point of connection of the two Licensed Distribution System Operators.
5. For transfers between a Transmission System operator and Generating Plant, the DMP shall be at the high voltage side of the generator transformers and station transformer(s).
6. For transfers between a Licensed Distribution System Operator and Generating Plant, the DMP shall be at the point(s) of connection of the generating station to the Licensed Distribution System Operator.
7. For transfers between a Licensed Distribution System Operator and a Customer, the DMP shall be at the point of connection to the Distribution System of the Licensed Distribution System Operator.
8. For transfers between a Transmission System operator and a Customer, the DMP shall be at the point of connection to the Transmission System operator.
9. For transfers between a Transmission System operator and an External System the DMP shall be as follows:-
  - (i) For the EdF link the busbar side of the busbar disconnectors at the Sellindge 400 kV Substation.

- (ii) For the Moyle Interconnector, the Converter Station side of the L15 circuit breaker on the Coylton feeder at Auchencrosh Substation.

Superseded

## APPENDIX B      LABELLING OF METERS FOR IMPORT AND EXPORT

A standard method of labelling Meters, test blocks, etc is necessary and based on the definitions for Import and Export the required labelling shall be as follows.

### 1      ACTIVE ENERGY

Meters or Meter Registers shall be labelled “Import” or “Export” according to the diagram “Figure 1”.

### 2      REACTIVE ENERGY

Within the context of this code the relationship between Active Energy and Reactive Energy can best be established by means of the power factor. The following table gives the relationship:-

Flow of Active Energy	Power Factor	Flow of Reactive Energy
Import	Lagging	Import
Import	Leading	Export
Import	Unity	Zero
Export	Lagging	Export
Export	Leading	Import
Export	Unity	Zero

Meters or Meter Registers for registering Import Reactive Energy should be labelled “Import” and those for registering Export Reactive Energy should be labelled “Export”.

APPENDIX B continued

FIGURE 1 IMPORT AND EXPORT ACTIVE ENERGY FLOWS CONVENTION

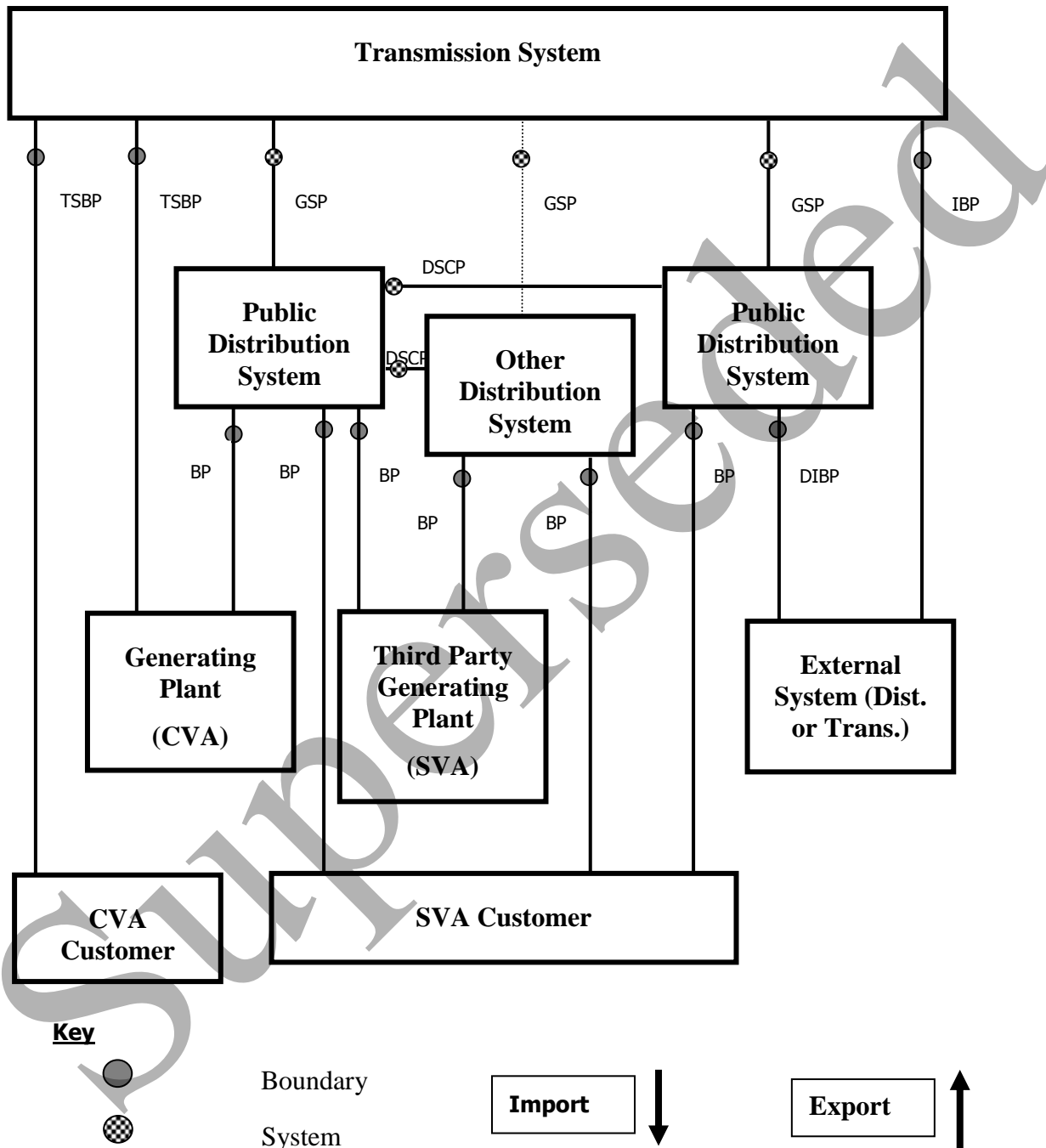

Import / Export Energy Flow Convention for the labelling of Meters  
 Import metering measures energy flows away from the Transmission System.  
 Export metering measures energy flows towards the Transmission System.  
 Energy flows between Distribution Systems is by bilateral agreement.



---

**Key to abbreviations used in Import / Export Diagram**

○	Metering Point
BP	Boundary Point
DIBP	Distribution Interconnector Boundary Point
DSCP	Distribution System Connection Point
GSP	Grid Supply Point
IBP	Interconnector Boundary Point
SCP	System Connection Point
TSBP	Transmission System Boundary Point

Superseded

## APPENDIX C FUSING

The following diagram shows a typical arrangement for the fusing requirements of this Code of Practice. The diagram is non-exhaustive and is provided for reference only.

**Figure 1:** Fusing arrangements<sup>7 8</sup>.

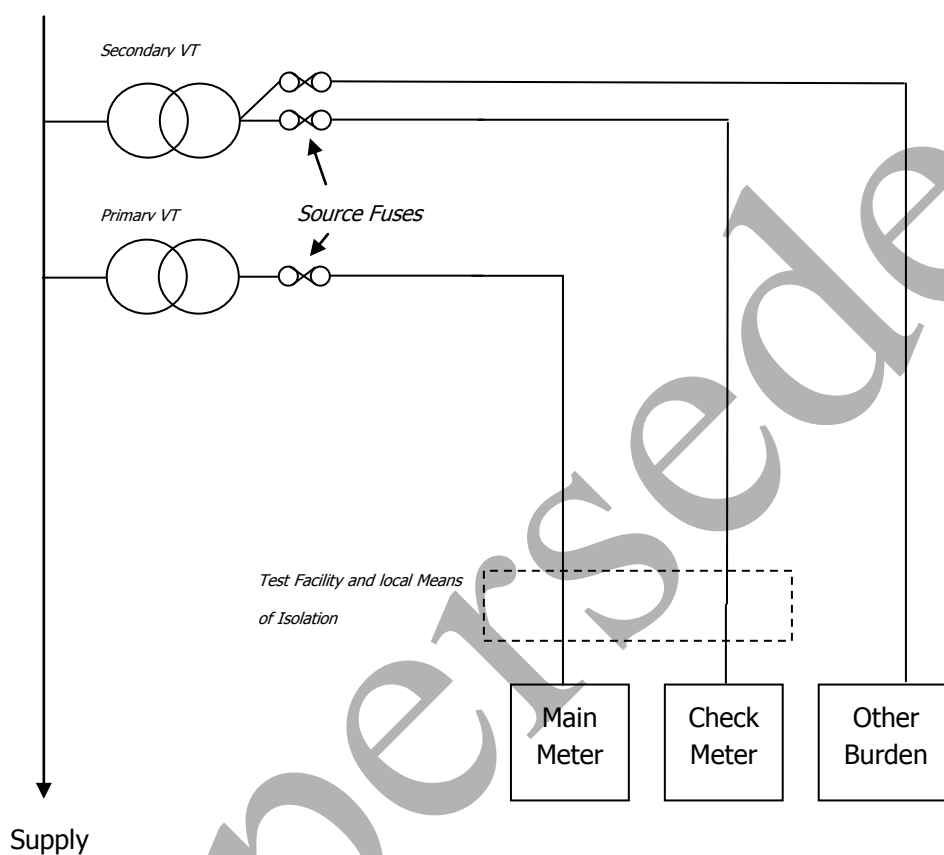

Note:

The boundary between Meter Operator Equipment and the Transmission/Distribution System Operator is between the local means of isolation and the testing facilities.

<sup>7</sup> Check Meters and other burden may be supplied via an additional secondary winding of the primary VT.

<sup>8</sup> Isolation may be provided by the use of solid links or fuses and may be located either side of the test terminal block. Where fuses are to be used, the additional burden shall be accounted for.

**APPENDIX D    PASSWORDS**

The Passwords specified in clause 5.6 shall be subject to the following additional requirements:

- i. The communications protocol employed shall ensure that the Password offered determines the level of access to the data within the Metering Equipment.
- ii. A counter to log the number of illegal attempts (i.e. Password comparison failures) to access Metering Equipment via the local and remote ports shall be incorporated into the log-on process. This counter shall reset to zero at every hour change (i.e. 0100, 0200 etc).
- iii. If the counter reaches 7, then access is prohibited at all levels until the counter resets at the next hour change.

---

## **APPENDIX E      GUIDANCE FOR THE USE OF MULTI CORE METERING CABLES**

Multi core cables are predominantly used to provide CT and VT signals to the Meter. However, such arrangements may cause additional errors that are not readily apparent to the Metering System designer. This guidance provides information that should be considered when using multi core cables for metering, particularly if used over long cable runs.

Consideration shall be given to the cross sectional area of the conductors of multi core cables:

- i. In CT circuits the cabling resistance is likely to represent an appreciable component of the CT burden and care should be taken to ensure that the CT overall burden is not exceeded;
- ii. For the VT circuits, cabling and fuses introduce high volt drop errors. Fuses with a low current rating tend to have a relatively high resistance value and are variable from fuse to fuse. Careful selection of fuses, fuse holders and the doubling of cores can be used to mitigate these effects.

The proximity of CT and VT signals in multi core cables can cause errors due to capacitive coupling from the voltage to the current circuits. The effect of this coupling is more prevalent at low loads with long cable runs, in particular with 1 amp rated CTs. One possible symptom of this condition is that the Meters may advance under no load conditions (circuit energised but with no load current). This coupling effect may be eliminated by careful allocation of cable core to function, or by running CT and VT signals in separate cables.