

CODE OF PRACTICE NINE

**CODE OF PRACTICE FOR THE METERING OF IMPORT AND
EXPORT ACTIVE ENERGY VIA LOW VOLTAGE CIRCUITS FOR
NON-HALF HOURLY SETTLEMENT PURPOSES**

Issue 1

Version 6.0

DATE: 24 February 2011

Code of Practice Nine

CODE OF PRACTICE FOR THE METERING OF IMPORT AND EXPORT ACTIVE ENERGY VIA LOW VOLTAGE CIRCUITS FOR NON-HALF HOURLY SETTLEMENT PURPOSES

1. Reference is made to the Balancing and Settlement Code for the Electricity Industry in Great Britain and, in particular, to the definitions of "Code of Practice" in Annex X.1 thereof.
2. This is Code of Practice Nine, Issue 1, Version 6.0.
3. This Code of Practice shall apply to Metering Systems comprising Metering Equipment that is subject to the requirements of Section L of the Balancing and Settlement Code.
4. This Code of Practice is effective from 24 February 2011.
5. This Code of Practice has been approved by the Panel.

Intellectual Property Rights, Copyright and Disclaimer

The copyright and other intellectual property rights in this document are vested in ELEXON or appear with the consent of the copyright owner. These materials are made available for you for the purposes of your participation in the electricity industry. If you have an interest in the electricity industry, you may view, download, copy, distribute, modify, transmit, publish, sell or create derivative works (in whatever format) from this document or in other cases use for personal academic or other non-commercial purposes. All copyright and other proprietary notices contained in the document must be retained on any copy you make.

All other rights of the copyright owner not expressly dealt with above are reserved.

No representation, warranty or guarantee is made that the information in this document is accurate or complete. While care is taken in the collection and provision of this information, ELEXON Limited shall not be liable for any errors, omissions, misstatements or mistakes in any information or damages resulting from the use of this information or action taken in reliance on it.

AMENDMENT RECORD

Issue	Date	Version	Description of Changes	Changes Included	Mods/ Panel/ Committee Refs
1	01/04/04	1.00	First Approved Issue	COPEG	
1	BETTA Effective Date	2.0	SVA February 05 Release; BSCCo	BETTA 6.3	SVG48/004
1	23/08/07	3.0	P197 Release; BSCCo	P197	P/115/04
1	26/02/09	4.0	February 09 Release	CP1251 CP1254	SVG93/02 SVG93/02 ISG93/02
1	26/11/09	5.0	Modification P230	P230	Panel
1	24/02/11	6.0	February 2011 Release	CP1342	SVG116/05

CODE OF PRACTICE FOR THE METERING OF IMPORT AND EXPORT ACTIVE ENERGY VIA LOW VOLTAGE CIRCUITS FOR NON-HALF HOURLY SETTLEMENT PURPOSES

CONTENTS

1.	SCOPE.....	6
2.	REFERENCES	8
3.	DEFINITIONS AND INTERPRETATIONS.....	9
3.1	ACTIVE ENERGY *	9
3.2	ACTIVE POWER *	9
3.3	CERTIFIED ‡.....	9
3.4	CURRENT TRANSFORMER ‡.....	9
3.5	DE-ENERGISED ‡.....	9
3.6	DEFINED METERING POINT ‡.....	10
3.7	DISTRIBUTION SYSTEM *	10
3.8	ELECTRICITY *	10
3.9	EXPORT †	10
3.10	IMPORT †	10
3.11	ISOLATING SWITCH ‡.....	10
3.12	METER *	10
3.13	METERING EQUIPMENT ‡.....	10
3.14	METER REGISTER ‡.....	11
3.15	RADIO TELESWITCH ‡.....	11
3.16	REGISTRANT *	11
3.17	SVA CUSTOMER *	11
3.18	TELEMETER ‡.....	11
3.19	TIMESWITCH ‡.....	11
4.	MEASUREMENT CRITERIA – WHOLE CURRENT METERS	12
4.1	MEASURED QUANTITIES.....	12
	<i>4.1.1 Measured Quantities</i>	<i>12</i>
4.2	ACCURACY REQUIREMENTS	12
	<i>4.2.1 Type Test Requirements</i>	<i>12</i>
	<i>4.2.2 Import Active Energy Accuracy Requirements (M1)</i>	<i>12</i>
	<i>4.2.4 Calibration.....</i>	<i>13</i>
	<i>4.2.5 In-service Accuracy limits.....</i>	<i>13</i>
	<i>4.2.6 Type approval</i>	<i>13</i>
5.	MEASUREMENT CRITERIA – CURRENT TRANSFORMER OPERATED METERS.....	14
5.1	MEASURED QUANTITIES.....	14
	<i>5.1.1 Measured Quantities.....</i>	<i>14</i>
5.2	ACCURACY REQUIREMENTS	14
	<i>5.2.1 Type Test Requirements</i>	<i>14</i>
	<i>5.2.2 Import Active Energy Accuracy Requirements (M1)</i>	<i>14</i>
	<i>5.2.3 Export Active Energy Accuracy Requirements (M2)</i>	<i>15</i>
	<i>5.2.4 Calibration.....</i>	<i>15</i>
	<i>5.2.5 In-service Accuracy limits.....</i>	<i>15</i>
	<i>5.2.6 Voltage supply for Current Transformer operated Meters</i>	<i>15</i>
	<i>5.2.7 Access to voltage supply and Meter terminals.....</i>	<i>15</i>
	<i>5.2.8 Current Transformers installed on new and existing circuits.....</i>	<i>15</i>
	<i>5.2.9 Access to Current Transformers</i>	<i>16</i>
	<i>5.2.10 Type approval.....</i>	<i>16</i>
6.	METERING EQUIPMENT CRITERIA	16
6.1	METERS.....	16
	<i>6.1.1 Metering configuration.....</i>	<i>17</i>
6.2	CURRENT TRANSFORMERS.....	17

- 6.3 REGISTERS, DISPLAYS AND FACILITIES..... 18**
 - 6.3.1 *Meters and Telemeters..... 18*
 - 6.3.2 *Displays 18*
 - 6.3.3 *Timeswitches and Internal Meter Time Clock..... 20*
 - 6.3.4 *Teleswitches..... 21*
 - 6.3.5 *Time keeping accuracy..... 21*
- 7. INSTALLATION OF METERS 21**
- 7.1 BSC QUALIFICATION REQUIREMENTS..... 21**
- 7.2 METER OPERATION CODE OF PRACTICE AGREEMENT REQUIREMENTS 21**
- 7.3 APPROPRIATE SEALS 21**
- 8. DEFINED METERING POINTS AND POINT OF SUPPLY 22**
- 8.1 RESPONSIBILITIES 22**
 - 8.1.1 *Distribution System Operator Responsibilities..... 22*
 - 8.1.2 *Meter Operator Agent Responsibilities..... 22*
- 8.2 MULTI-RATE WHOLE CURRENT METER – WHERE THE SVA CUSTOMER’S INSTALLATION DOES NOT DIRECTLY CONNECT WITH THE INSTALLED METER(S)..... 22**
 - 8.2.1 *Installations with an Isolating Switch..... 22*
- 8.3 OTHER REQUIREMENTS 25**
 - 8.3.1 *Anti Fraud Devices 25*
 - 8.3.2 *Outside Meter Cabinets 25*
 - 8.3.3 *High Risers and Laterals 25*
- 8.4 CURRENT TRANSFORMER OPERATED METERING EQUIPMENT 25**
 - 8.4.1 *Provision of Test and Isolation facilities 25*
 - 8.4.2 *Interface between Meter Operator Agent and Distribution System Operator 26*
 - 8.4.3 *SVA Customer cabling 26*
- 9. PROVISION OF METERING EQUIPMENT 27**

FOREWORD

This Code of Practice defines the minimum requirements for whole current and transformer operated Metering Equipment at the Defined Metering Point for the measurement of Import and Export Active Energy via low voltage circuits for Non-Half Hourly Settlement purposes.

BSCCo shall retain copies of, inter alia, the Code of Practice together with copies of all documents referred to in them, in accordance with the provisions of the Balancing and Settlement Code (the Code).

1. SCOPE

This Code of Practice states the practices that shall be employed and the facilities that shall be provided for the measurement and recording of the quantities required for Settlement and other purposes. This Code of Practice does not currently cover the measurement of gross generation.

This Code of Practice specifically applies to whole current and transformer operated Metering Equipment to be installed **FOR THE METERING OF IMPORT AND EXPORT ACTIVE ENERGY VIA LOW VOLTAGE CIRCUITS FOR NON-HALF HOURLY SETTLEMENT PURPOSES.**

This Code of Practice only applies to whole current and current transformer operated Metering Equipment for Import and Export Active Energy measured in kWh. No provision is made for the measurement of Reactive or Apparent Energy or any Maximum Demand.

The following areas are not specified within this Code of Practice:

MOA arrangements where more than one MOA exists at a Site;

Prepayment Metering;

Complex Tariff Arrangements;

Revenue Protection/Security; and

Data Communications.

This Code of Practice defines the extent of Metering Equipment to be installed by a Meter Operator Agent in fulfilling its role in the installation and maintenance of equipment for Non-Half Hourly Settlement purposes.

This Code of Practice derives force from the Balancing and Settlement Code, and in particular the metering provisions contained in Section L, to which reference should be made. It should also be read in conjunction with the relevant BSC Procedures.

Metering Equipment that meets the requirements of this Code of Practice is not applicable where a Registrant is required by its Supply Licence (and as referenced in Section L3.2.6) to install Metering Equipment that is capable of providing measured electricity consumption data for multiple periods (at least half hourly) and providing the Registrant with remote access to such data.

This Code of Practice does not contain the calibration, testing and commissioning requirements for Metering Equipment used for Settlement purposes. These requirements are detailed in Code of Practice Four - "Code of Practice for Calibration, Testing and Commissioning Requirements for Metering Equipment for Settlement Purposes".

Any device that is not covered by SI1679 shall not be involved in deriving the KWh value for Settlement purposes. To clarify, an integral Outstation may be used but a remote outstation (peripheral device) that derives a KWh value (e.g. via pulsed outputs) shall not be used. A remote outstation that transfers the KWh value of the primary register in accordance with the manufacturers protocol may be used.

Dispensations from the requirements of this Code of Practice may be sought in accordance with the Balancing and Settlement Code and BSCP32.

In the event of an inconsistency between the provisions of this Code of Practice and the Balancing and Settlement Code, the provisions of the Balancing and Settlement Code shall prevail.

Compliance with this Code of Practice may be attained by the use one of the following techniques:

- (i) a single Meter containing measuring elements for Import and Export ; or
- (ii) two separate Meters containing a single measuring element for each of Import and Export.

2. REFERENCES

The following documents are referred to in the text:-

BS EN 62053:2003	Electricity metering equipment (a.c.)
BS EN 61038: 1993	Specification for time switches for tariff and load control.
BS 7856: 1996	‘Code of Practice for Design of Alternating Current Watt-Hour Meters for Active Energy (Classes 1 and 2)’
BS 7951:2000	‘Electricity Meters. Alternating current single phase watt-hour Telemeters of accuracy class 1 or 2.’
BS EN 60044-1:1999	‘Instrument Transformers – Part 1: Current Transformers’
BEBS 1973	Timeswitches, restricted hour and time of day tariffs.
Balancing and Settlement Code	‘Section X; Annex X-1 and Sections L and S’
BSC Procedures List	‘See BSC Section H 1.3.2 (a) – Code Subsidiary Documents’
Code of Practice Four	‘Code of Practice for Calibration, Testing and Commissioning Requirements for Metering Equipment for Settlement Purposes’
Electricity Act 1989	‘Schedule 7, as amended by Schedule 1, to the Competition and Services (Utilities) Act 1992.’
Statutory Instrument 2002 No. 2665	‘The Electricity Safety, Quality and Continuity Regulations 2002’
Statutory Instrument 1998 No. 1565	The Meters (Approval of Pattern or Construction and Manner of Installation) Regulations 1998.
Statutory Instrument 1998 No.1566	‘Electricity – The Meters (Certification) Regulations 1998.’
Meter Operation Code of Practice Agreement ¹	‘Agreement between Meter Operators and Distribution Businesses governing arrangements for safety and technical competence’
BS 7647 (1993)	‘Specification for Radio Teleswitches for tariff and load control’
Utilities Act 2000	‘Utilities Act 2000’
Statutory Instrument 2006 No.1679	The Measuring Instruments (Active Electrical Energy meters) Regulations 2006 (SI 2006/1679)

¹ The Meter Operation Code of Practice Agreement is a voluntary agreement between Licenced Distribution System Operators and Meter Operator Agents.

3. DEFINITIONS AND INTERPRETATIONS

Save as otherwise expressly provided herein, words and expressions used in this Code of Practice shall have the meanings attributed to them in the Balancing and Settlement Code and are included for the purpose of clarification.

Note: * indicates definitions in the Balancing and Settlement Code.

Note: † indicates definitions which supplement or complement those in the Balancing and Settlement Code.

Note: ‡ indicates definitions specific to this Code of Practice

3.1 Active Energy *

Active Energy means the electrical energy produced, flowing or supplied by an electric circuit during a time interval, being the integral with respect to time of the instantaneous Active Power, measured in units of watt-hours or standard multiples thereof.

3.2 Active Power *

Active Power means the product of voltage and the in-phase component of alternating current measured in units of watts and standard multiples thereof, that is:-

1,000 Watts = 1 kW

1,000 kW = 1 MW

3.3 Certified ‡

Certified means a meter conforming with the Statutory Instrument, 1998 No.1566 "Electricity – The Meters (Certification) Regulations".

3.4 Current Transformer ‡

A transformer for use with electrical measuring instruments, electrical protection and/or control equipment, for the transformation of current and in which the current in the secondary winding, in normal conditions of use, is substantially proportional to the current in the primary winding and different from it by an angle which approaches zero for an appropriate direction of the connections.

3.5 De-Energised ‡

De-Energised means the temporary removal of the supply at a Defined Metering Point (e.g. the main circuit connections to the Licenced Distribution System Operator's network are still made) such that all or part of the Metering Equipment is considered to be temporarily "inactive" for the purposes of Settlement. e.g. unoccupied premises where the incoming switchgear has been opened or the cut-out fuse(s) removed and any generation disconnected.

3.6 Defined Metering Point ‡

Defined Metering Point means the physical location at which the overall accuracy requirements as stated in this Code of Practice are to be met. The Defined Metering Points are identified in section 8.

3.7 Distribution System *

- (i) any Public Distribution System; and
- (ii) any other distribution system in Great Britain for which the condition is satisfied that all entry/exit points are subject to registration in SMRS pursuant to the provisions of the MRA; where:
 - (1) 'distribution system' has the meaning given or to be given to that term in section 4(4) of the Act, following amendment of the Act by section 28 of the Utilities Act 2000;
 - (2) 'entry/exit point' means a point at which electricity may flow on to or off such distribution system other than from or to the Transmission System or another such system or a Public Distribution System;

3.8 electricity *

"electricity" means Active Energy and Reactive Energy.

3.9 Export †

Export means, for the purpose of this Code of Practice, a net Active Energy flow towards the Transmission System. (i.e. At a Customer's premises, a power flow away from the Customer's installation.)

3.10 Import †

Import means, for the purposes of this Code of Practice, a net Active Energy flow away from the Transmission System. (i.e. At a Customer's premises, a power flow towards the Customer's installation.)

3.11 Isolating Switch ‡

means a switch located between a Meter and customer's fuse box and providing a means of isolating the electricity supply to the customer's fuse box and which may be operated by the customer or their electrical contractor.

3.12 Meter *

Meter means a device for measuring Active Energy and/or Reactive Energy.

3.13 Metering Equipment ‡

Metering Equipment means Meters, Telemeters, Timeswitches, Radio Teleswitches, Isolating Switches, connector blocks, test terminal blocks, measurement transformers

(voltage, current or combination units), metering protection equipment including alarms, circuitry, associated Communications Equipment and Outstation and wiring.

3.14 Meter Register ‡

Meter Register means a device, associated with a Meter, from which it is possible to obtain a reading of the amount of Active Energy that has been supplied by a circuit.

3.15 Radio Teleswitch ‡

means a timing device for tariff and/or load control purposes, utilising a time base derived from, and maintained by, a radio signal in accordance with specification BS 7647 (1993).

3.16 Registrant *

Registrant means in relation to a Metering System, the person for the time being registered in CMRS or (as the case may be) SMRS in respect of that Metering System pursuant to Section K of the Balancing and Settlement Code.

3.17 SVA Customer *

means a person to whom electrical power is provided, whether or not that person is the provider of that electrical power; and where that electrical power is measured by a SVA Metering System.

3.18 Telemeter ‡

means a combined Meter and Radio Teleswitch.

3.19 Timeswitch ‡

means a timing device for tariff and/or load control purposes, utilising a time base derived from either mains frequency or an internal crystal controlled clock.

4. MEASUREMENT CRITERIA – WHOLE CURRENT METERS

4.1 Measured Quantities

See section 6.1.1 for a description of the acronyms M1 and M2.

4.1.1 Measured Quantities

- (i) Import Active Energy (M1) in kWh.
- (ii) Export Active Energy (M2) in kWh.

Registers shall be provided in accordance with clause 6.3.1.

4.2 Accuracy Requirements

4.2.1 Type Test Requirements

Meters shall be type tested in accordance with 4.2.6 and satisfy the requirements of BS 7951:2000 or BS EN 62053:2003 as appropriate.²

4.2.2 Import Active Energy Accuracy Requirements (M1)

- (i) Meter Accuracy

CONDITION	LIMIT OF ERRORS AT STATED SYSTEM POWER FACTOR	
	Power Factor	Limits of Error
100% I_{max} * to 10% I_b inclusive	1	± 2.0%

* I_{max} shall be rated at 80 amps or greater.

² For the purpose of separate Export Meters the LDSO system is to be regarded as the load

4.2.3 Export Active Energy Accuracy Requirements (M2)³

(i) Meter Accuracy

CONDITION	LIMIT OF ERRORS AT STATED SYSTEM POWER FACTOR	
	Power Factor	Limits of Error
100% I _{max} * to 10% I _b inclusive	1	± 2.0%

* I_{max} shall be rated at 80 amps or greater.

4.2.4 Calibration

Meters shall be calibrated to the limits of error prescribed in the Statutory Instrument 1998 No.1566; 'Electricity – The Meters (Certification) Regulations 1998', clause 3(2)(c).

4.2.5 In-service Accuracy limits

The overall accuracy of the energy measurements at, or referred to, the Defined Metering Point shall at all times be within the limits of error for in-service accuracy.

The overall in-service accuracy limits are +2.5% to –3.5% at any load at which the Metering Equipment is designed to operate.

4.2.6 Type approval

Meters shall have been tested and received type approval in accordance with the Statutory Instrument 1998 No.1565; 'The Meters (Approval of Pattern or Construction and Manner of Installation) Regulations 1998, to a standard not less than Class 2 applicable at the time of type approval.

³ With balanced loads for polyphase meters

5. MEASUREMENT CRITERIA – CURRENT TRANSFORMER OPERATED METERS

5.1 Measured Quantities

See section 6.1.1 for a description of the acronyms M1 and M2.

5.1.1 Measured Quantities

- (i) Import Active Energy (M1) in kWh.
- (ii) Export Active Energy (M2) in kWh.

5.2 Accuracy Requirements

5.2.1 Type Test Requirements

Meters shall be type tested in accordance with 4.2.6 and satisfy the requirements of BS 7951:2000 or BS EN 62053:2003 as appropriate.²

5.2.2 Import Active Energy Accuracy Requirements (M1)³

- (i) Meter Accuracy

CONDITION	LIMIT OF ERRORS AT STATED SYSTEM POWER FACTOR	
	Power Factor	Limits of Error
100% I_{\max} to 5% I_n inclusive	1	$\pm 2.0\%$

5.2.3 Export Active Energy Accuracy Requirements (M2)

(i) Meter Accuracy

CONDITION	LIMIT OF ERRORS AT STATED SYSTEM POWER FACTOR	
Current	Power Factor	Limits of Error
100% I_{max} to 5% I_n inclusive	1	$\pm 2.0\%$

5.2.4 Calibration

Meters shall be calibrated to the limits of error prescribed in Statutory Instrument 1998 No.1566; 'Electricity – The Meters (Certification) Regulations 1998', clause 7(2).

5.2.5 In-service Accuracy limits

The overall accuracy of the energy measurements at, or referred to, the Defined Metering Point shall at all times be within the limits of error for in-service accuracy.

The overall in-service accuracy limits are +2.5% to –3.5% at any load at which the Meter Equipment is designed to operate.

5.2.6 Voltage supply for Current Transformer operated Meters

A separately fused voltage supply shall be provided between the cut-out and the Current Transformer operated Meter. Where the Meters for M1 and M2 are separate, then only a single secondary fuse (2 or 6 amp) shall be fitted per phase to serve both Meters. No burden other than Metering Equipment shall be connected to the fused side of the voltage supply. The neutral conductor of the voltage supply to the Meter shall not be fused.

5.2.7 Access to voltage supply and Meter terminals

Access to the voltage supply fuse(s) and Meter terminals shall only be possible by the breaking of a seal.

5.2.8 Current Transformers installed on new and existing circuits

Where circuits other than those newly installed, are to be metered to this Code of Practice and where the installed Current Transformers do not comply with the Class accuracies specified in clause 6.2, then such Current Transformers may be used providing the following requirements and those in clause 5.2.5 are met and that where subsequently an alteration to the Metering Equipment is carried out, new Current Transformer(s) shall be provided to meet the accuracy requirements specified in clause 6.2 below.

5.2.9 Access to Current Transformers

Access to both the primary and secondary sides of Current Transformers shall only be possible by the breaking of a seal. Where 'open ring' Current Transformers are used, measures shall be taken to prevent unauthorised access to the central aperture, such that no additional conductors may be passed through the aperture without the breaking of a seal.

5.2.10 Type approval

Meters shall have been tested and received type approval in accordance with the Statutory Instrument 1998 No.1565; 'The Meters (Approval of Pattern or Construction and Manner of Installation) Regulations 1998, to a standard not less than Class 2 applicable at the time of type approval.

6. METERING EQUIPMENT CRITERIA

Metering Equipment shall be accommodated in a clean and dry environment.

For each circuit, other than one which is de-energised, the voltage supply to any Meters and Displays shall be connected such that it is normally energised to facilitate reading of the Meter Register(s).

6.1 Meters

The Meters may be either static or induction disc types.

No register shall be permitted to decrement in the event of energy flow in an opposing direction.

For each circuit, Import Active Energy Meters (M1) shall be supplied which shall meet the requirements of BS 7856 and either BS EN 61036 Class 2 or BS EN 60521 Class 2 or BS 7951:2000.

Import Active Energy Meters (M1) provided for the metering of supplies to Customers shall be in accordance with Schedule 7 of the Electricity Act 1989.

For each circuit, Export Active Energy Meters (M2) shall be supplied which shall meet the requirements of BS 7856 and either BS EN 61036 Class 2 or BS EN 60521 Class 2 or BS 7951:2000.

Import and Export Active Energy Meters (M1 and M2) shall be configured such that the number of measuring elements is equal to or one less than the number of primary system conductors. These include the neutral conductor, and/or the earth conductor where system configurations enable the flow of zero sequence energy. The Meter and any Current Transformers shall be of a rating appropriate to the installation.

Where separate Meters are installed for Import and Export they shall be clearly identified and labelled accordingly.

Where the Import Active Energy Meter (M1) is a polyphase Meter the meter used for Export shall also be polyphase so that the net energy is measured in both cases.

All programmable Meters shall have a security regime to minimise unauthorised access to data and configuration changes.

6.1.1 Metering configuration

Throughout this Code of Practice the Measurement Quantities have been identified by the simple acronyms M1 and M2.

M1 may be regarded as the measuring element(s) from which the Import Active Energy is derived and calculated.

M2 may be regarded as the measuring element(s) from which the Export Active Energy is derived and calculated.

In practice M1 and M2 may be the same measuring element(s), but recording power flows in opposite directions.

Schematic diagram of a combined Import and Export Meter – Whole Current

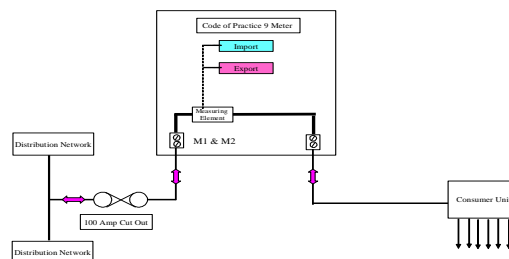

6.2 Current Transformers

The term "Current Transformer" used in Section 5 does not preclude the use of other measuring techniques with a performance equal to that specified for such measurement transformers.

For each circuit where a Current Transformer is used, it shall meet the requirements set out below.

Where required, one set of Current Transformers to BS EN 60044-1:1999 with a minimum standard of accuracy to Class 0.5 shall be provided per circuit. Preferably the Current Transformers shall be dedicated for Settlement purposes, but the Current Transformers may be used for other purposes provided the overall accuracy requirements in clause 5.2.4 are met.

The total burden on each Current Transformer shall not exceed the rated burden of such Current Transformer.

The orientation of the Current Transformers shall be such that the P1 face is towards the Distribution Network.

6.3 Registers, Displays and Facilities

Either of the two methods for meeting the requirements of this Code of Practice may be employed, as indicated in clause 6.3.1 below.

6.3.1 Meters and Telemeters

- (a) Import and Export rate registers for a combined Import and Export Meter shall be provided for:
- (i) the total Import Active Energy and the total Export Active Energy measured by that Meter/Telemeter; and
 - (ii) each rate measured by a multi-rate Import and Export Active Energy Meter/Telemeter. The sum of such multi-rate registers shall be equal⁴ to the total Import and Export Active Energy measured by that Meter/Telemeter.

Note: Where more than one rate register is employed per Energy flow, a total register need not be provided for that Energy flow.

- (b) Import and Export rate registers for separate Import and Export Meters shall be provided and sum of all rate register advances shall be equal⁴ to the total Import and total Export Active Energy measured by that Meter/Telemeter.

6.3.2 Displays

The Metering Equipment shall display the Import and Export Active Energy in kWh for each register utilised on the Meter (not necessarily simultaneously).

All currently active registers shall be identifiable. All other registers utilised by the applicable tariff shall be displayed.

Each register shall be clearly identified by a two digit ID in accordance with the Table below. Where a Meter does not provide a two digit ID an indication showing its conversion to the following Table shall be affixed to the Meter.

⁴ Allowance shall be made for fractions of kWh measured by each register, not being included in the total Import or Export Active Energy calculation.

Display Register Function and Rate IdentifiersBlock allocation

Register ID Blocks	Function
00 to 09 ⁵	Date, Time, Serial Number and other functions
10 to 19	Electricity (Import)
20 to 29	Electricity (Export)
30 to 39	Future use
40 to 49	Future use
50 to 59	Future use
60 to 69	Future use
70 to 79	Future use
80 to 89	Future use
90 to 99	Future use

Rate Identifiers Block 00 to 09

Register ID	Function
00	Serial Number ⁵ Printed on Meter case and within any electronic data transmission.
01 ⁶	Current date (dd-mm-yy)
02 ⁶	Current time (hh:mm:ss) GMT
03	Future use
04	Future use
05	Future use
06	Future use
07	Future use
08	Future use
09	Future use

⁵ Provision shall be made for a Serial Number length of 16 characters.

⁶ Current Date and Time shall be displayed where appropriate.

Rate Identifiers Block 10 to 19

Register ID	Function
10	Total Import Register
11	Rate 1 Import Register
12	Rate 2 Import Register
13	Rate 3 Import Register
14	Rate 4 Import Register
15	Rate 5 Import Register
16	Rate 6 Import Register
17	Rate 7 Import Register
18	Rate 8 Import Register
19	Rate 9 Import Register

Rate Identifiers Block 20 to 29

Register ID	Function
20	Total Export Register
21	Rate 1 Export Register
22	Rate 2 Export Register
23	Rate 3 Export Register
24	Rate 4 Export Register
25	Rate 5 Export Register
26	Rate 6 Export Register
27	Rate 7 Export Register
28	Rate 8 Export Register
29	Rate 9 Export Register

6.3.3 Timeswitches and Internal Meter Time Clock

Timeswitches, where required, shall be installed and the time set to the time standard (GMT or BST) as required by the Supplier's tariff requirements.

Timeswitches and internal Meter time clocks, where required, shall be set as close as reasonably practical to the time standard required by the Supplier's tariff requirements.

The rate switching times for the Import registers shall be capable of independent control of the rate switching times for the Export registers.

6.3.4 Teleswitches

Teleswitches, where required, shall be installed and set to the appropriate Application/User/Group Code in accordance with the Supplier's tariff requirements.

Provision shall be made for different Group Codes to be assigned to the Import and Export registers.

6.3.5 Time keeping accuracy

Timeswitches shall be maintained to an accuracy of ± 2 hours.

7. INSTALLATION OF METERS

7.1 BSC Qualification requirements

A Supplier is required by the Balancing and Settlement Code only to use Qualified Persons for the purposes of providing meter operation services. Full details of the procedure are available in BSCP537 from the BSC Website “ www.elexon.co.uk ”.

7.2 Meter Operation Code of Practice Agreement requirements

The Meter Operation Code of Practice Agreement covers the installation, operation and maintenance of Metering Equipment by Meter Operator Agents. It identifies the safety and technical requirements relevant to meter operation, and the interface between a Meter Operator Agent and a Distribution System Operator. It specifies the requirements for both the Metering Business and field staff as appropriate.

The principles within the Meter Operation Code of Practice Agreement form the basis of good practice for meter installation, operation and maintenance at any site that is connected, either to a Distribution System or to any other network.

A party's compliance with the Meter Operation Code of Practice Agreement is regulated and policed by the Registration Authority⁷.

7.3 Appropriate Seals

All SVA Customers Metering Equipment shall be sealed in accordance with Appendix 8 and 9 of the Meter Operation Code of Practice Agreement and any applicable BSCP.

⁷ The Registration Authority is defined within the Meter Operation Code of Practice Agreement.

8. DEFINED METERING POINTS AND POINT OF SUPPLY

8.1 Responsibilities

8.1.1 Distribution System Operator Responsibilities

The Distribution System Operator is responsible for the service cable and the cut-out.

8.1.2 Meter Operator Agent Responsibilities

The Meter Operator Agent shall install the Meter/s.

The conductors between the cut-out and the input terminals of the Meter shall be installed by, and be the responsibility of, the Meter Operator Agent.

The conductors between the Meter's outgoing terminals and the consumer unit will be part of the SVA Customer's installation but the responsibility of the Meter Operator Agent for connection.

8.2 Multi-rate Whole Current Meter – where the SVA Customer's installation does not directly connect with the installed Meter(s).

8.2.1 Installations with an Isolating Switch

Where an installation has an additional Meter, a timeswitch, teleswitch, or external isolating switch, then the Meter Operator Agent shall install these items. Also, the interconnecting wiring between the items up to the last item of equipment, for example an isolating switch or Meter before the 'consumer unit', would be installed and maintained by the Meter Operator Agent. However, any wiring between the final item of equipment and the 'consumer unit' would be part of the SVA Customer's installation.

Note:

The diagrams in this section of the Code of Practice are single phase examples only. These diagrams should not be taken as definitive wiring diagrams for any installation.

Multi-rate Whole Current installation with a combined M1 and M2 Meter with Isolating Switches

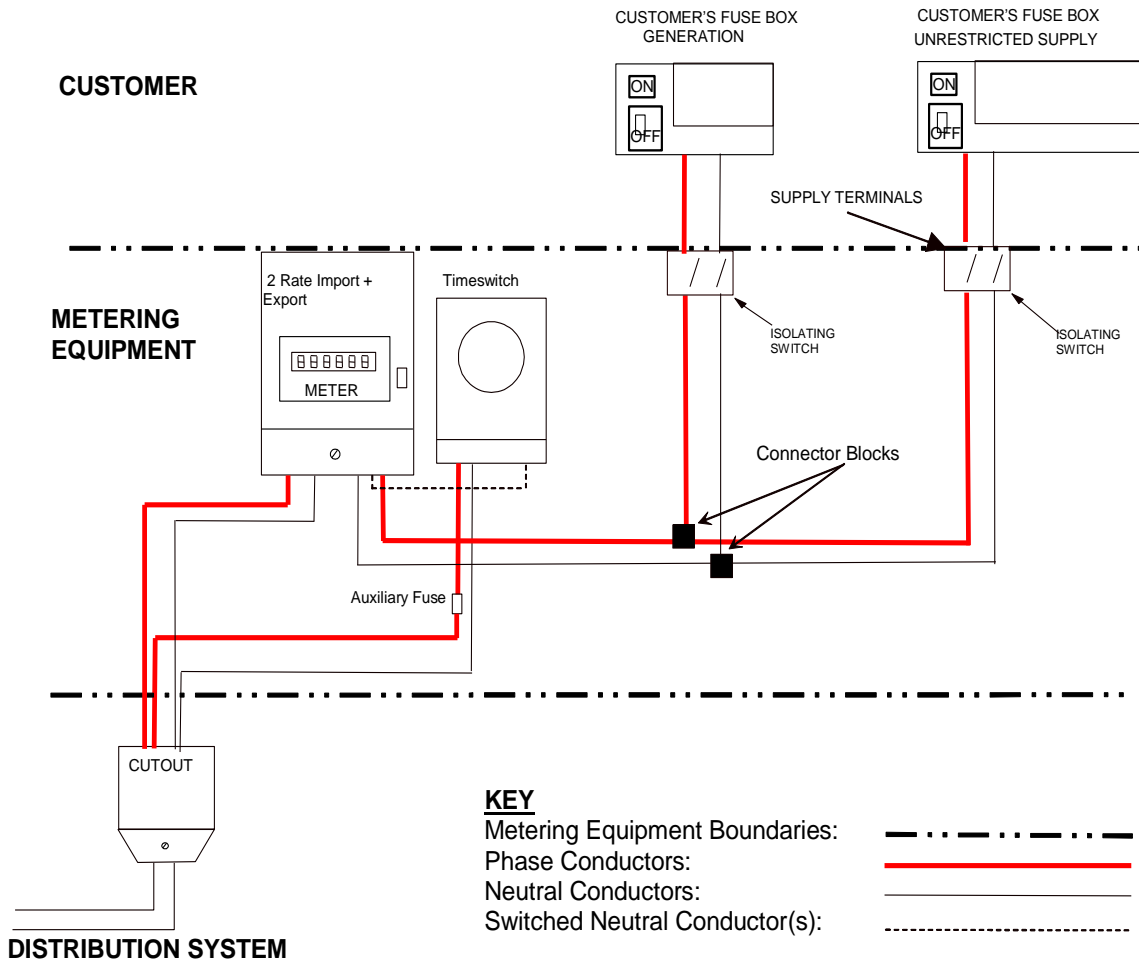

Multi-rate Whole Current installation with separate M1 and M2 Meters with Isolating Switches

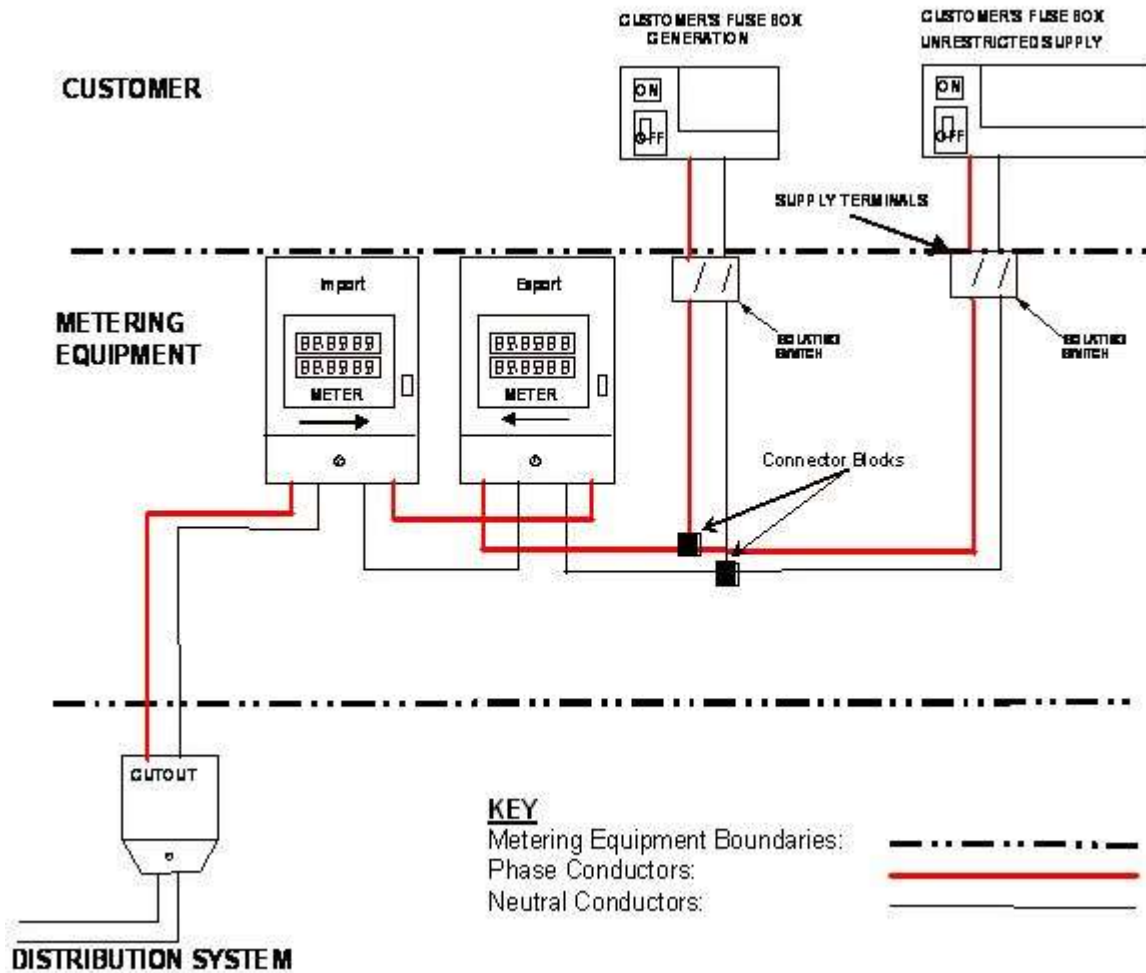

Multi-rate Whole Current Meter with Isolating Switches and controlled Load

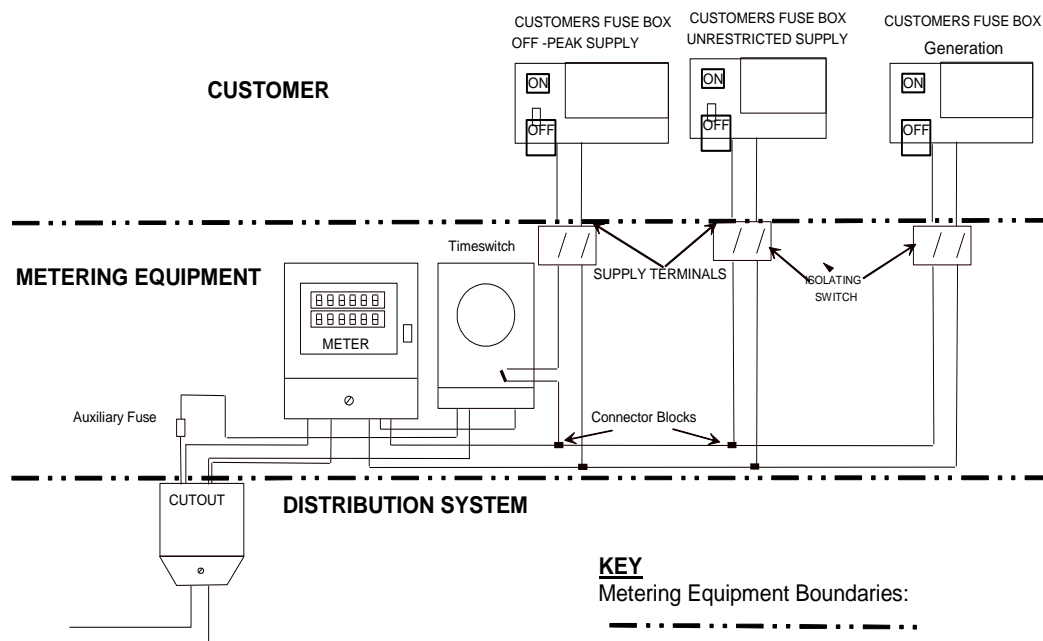

8.3 Other Requirements

8.3.1 Anti Fraud Devices

Where considered necessary by the Supplier, anti-fraud devices such as security blocks fitted between the cut-out and the meter, and plastic bubbles would be supplied and fitted by the Meter Operator Agent.

8.3.2 Outside Meter Cabinets

An outside meter cabinet will normally be considered the Customer's property and their responsibility to replace in the event of it being damaged.

8.3.3 High Risers and Laterals

Where the metering is situated within a communal metering area the risers are normally privately owned.

Where the metering is situated in the individual flats then the risers are normally owned by the Distribution System Operator.

8.4 Current Transformer Operated Metering Equipment

8.4.1 Provision of Test and Isolation facilities

For the purposes of meter connection by the Meter Operator Agent, the Current Transformers, meter panel, associated multicore cable, test/isolating facilities and

voltage fuses will be provided by the Distribution System Operator or a contractor nominated by the SVA Customer.

8.4.2 Interface between Meter Operator Agent and Distribution System Operator

In normal circumstances the Meter Operator Agent to Distribution System Operator interface point will be the outgoing connections from the test/isolating facilities and the metering panel voltage fuses.

8.4.3 SVA Customer cabling

The cabling from the Distributor System Operator's cut-out or main fuse, through Current Transformers and into a SVA Customer's main switch is the property of the SVA Customer.

Current Transformer Operated Metering Equipment

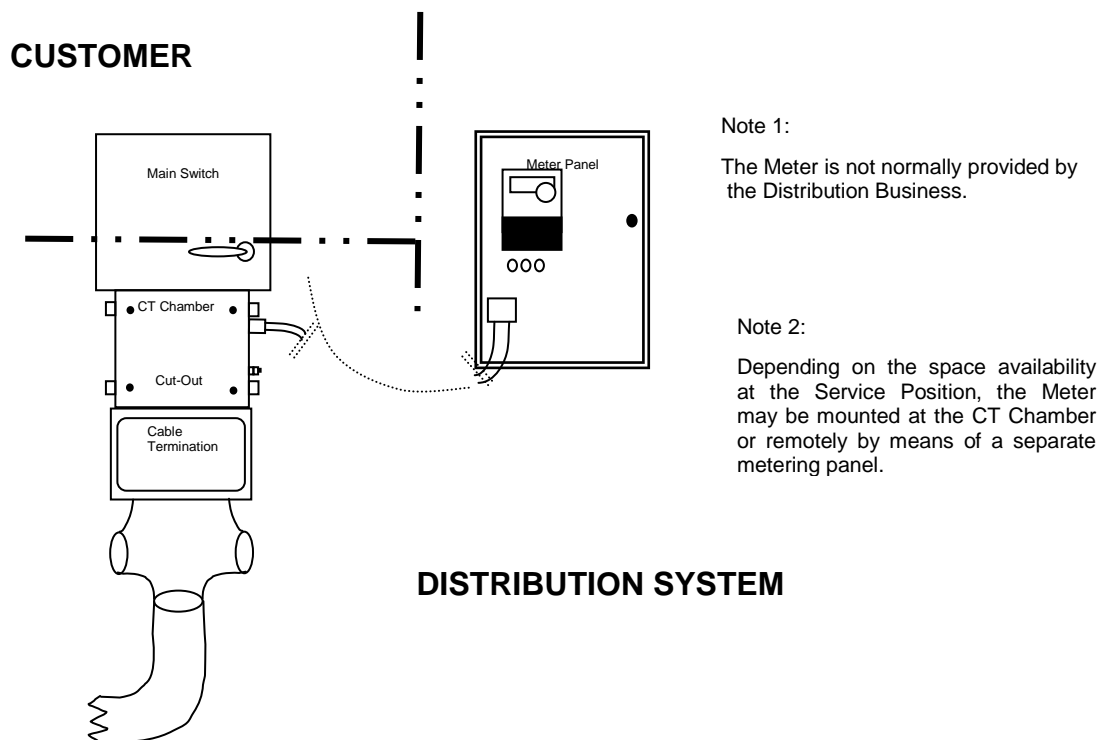

9. PROVISION OF METERING EQUIPMENT

The table below is for guidance on the provision and responsibility of selected items in any particular installation.

The term Equipment Owner (EO) has been used to identify the party responsible for providing the item of Meter Equipment or associated / ancillary equipment.

Note:- Not all items in the following table will be present in all installations.

Table defining responsibilities for various items of Metering Equipment

Item	Provider of equipment	Field work Responsibility
(A) <u>All installations</u>		
Service cable	LDSO	LDSO
High Risers and Laterals	EO or landlord	LDSO
Cut-out	LDSO	LDSO
Main fuses (cut-out fuses)	LDSO	LDSO or MOA*
Circuit Breaker (or equivalent) (for larger installations)	LDSO	LDSO or MOA*
Meter / Telemeter	EO	MOA
Timeswitch	EO	MOA
Teleswitch	EO	MOA
(B) <u>Whole current installations</u>		
Cables: cut-out to meter	EO	MOA
Cables: from meter to SVA Customer owned switchgear	SVA Customer/contractor	MOA* to connect
Isolating switch	EO	MOA
Connector blocks	EO	MOA
Cables: between meter and other EO supplied apparatus or between other items of EO supplied apparatus	EO	MOA
Revenue Protection equipment	Supplier/EO	MOA

Cables: between Revenue Protection equipment and other apparatus	Supplier/ EO	MOA
(C) <u>Current Transformer operated installations</u>		
Current Transformers	LDSO	LDSO
Meter panel	LDSO	LDSO
Test terminal block	LDSO	LDSO
Potential fuses at source	LDSO	LDSO
Potential fuses or isolators on meter panel	LDSO	LDSO
Additional potential fuses for meters or other apparatus	EO	MOA
Multicore and all cabling between source and meter panel	LDSO	LDSO
Cables: beyond test terminal block and potential fuses	EO	MOA
Cables: cut-out (or Circuit Breaker) to SVA Customer's mainswitch	SVA Customer/contractor	MOA* to connect

MOA* means MOA may operate this equipment under the terms of the Meter Operation Code of Practice Agreement.

Note: Use of the Table above in respect of ownership, provision, specification and ongoing maintenance of CT chambers, metering panels, isolating switches and rising mains should be confirmed with the relevant LDSO. The Table illustrates the typical arrangements, but cannot be relied upon as being definitive in every circumstance.