

Schedule 19
Chapter 2
Metering Code of Practice S2
Code for the Metering of Circuits with a rated capacity
not exceeding 100 MVA for Allocation purposes
Issue 1

Shepherd & Wedderburn WS



Saltire Court
20 Castle Terrace
Edinburgh EH1 2ET

Tel: 0131-228 9900
Fax: 0131-228 1222

155 St Vincent Street
GLASGOW
G2 5NR

Tel: 0141-566 9900
Fax: 0141-565 1222

**CODE FOR THE METERING OF CIRCUITS WITH A RATED
CAPACITY NOT EXCEEDING 100MVA
FOR ALLOCATION PURPOSES**

1.	Scope	2
1.1	<i>Scope</i>	2
1.2	<i>Extent</i>	2
1.3	<i>Derogations</i>	2
1.4	<i>Responsibility</i>	2
1.5	<i>Nominated agent</i>	2
2.	References	3
2.1	<i>References</i>	3
3.	Definitions	4
3.1	<i>Definitions</i>	4
4.	Measurement Criteria	4
4.1	<i>Measured quantities and Demand Values</i>	4
4.1.1	Measured quantities	4
4.1.2	Demand Values	4
4.2	<i>Accuracy requirements</i>	5
4.2.1	Overall accuracy	5
4.2.2	Compensation for measurement transformer error	6
4.2.3	Compensation for power transformer and line losses	6
5.	Metering Equipment criteria	7
5.1	<i>Measurement transformers</i>	8
5.1.1	Current transformers	8
5.1.2	Voltage transformers:	9
5.1.3	Monitoring of voltage transformers:	10
5.1.4	Measurement transformers installed on existing circuits:	10
5.2	<i>Fusing and Testing facilities</i>	11
5.3	<i>Meters</i>	11

5.4	<i>Displays and facilities for Settlement Information</i>	13
5.4.1	Displays	13
5.4.2	Facilities for Responsible Party use	14
5.5	<i>Outstation</i>	15
5.5.1	Data storage	15
5.5.2	Time keeping	17
5.5.3	Monitoring facilities	17
5.6	<i>Communications</i>	18
5.7	<i>Local interrogation</i>	20
5.8	<i>Remote interrogation</i>	20
5.9	<i>Appropriate seals</i>	21
6.	Associated Facilities	21
6.1	<i>Interrogation Unit</i>	21
6.2	<i>Additional features</i>	22
7.	Access to Data	22
7.1	<i>Access</i>	22
	Appendix A - Defined Metering Points	23
	<i>Defined Metering Point:</i>	23
	Appendix B - Labelling of Meters for Import and Export	24
	<i>Standard method</i>	24
	Appendix C - Typical Testing Facilities and Fusing Arrangements	26
	Appendix D - Responsible Party Passwords	27
	Appendix E - Options for ensuring Meters and Displays can be read and remotely interrogated	28
	<i>Figure 2</i>	30
	Appendix F - Generic Derogations	31
	<i>summation CTs</i>	31
	<i>position of metering</i>	31

<i>passwords</i>	31
<i>sealing of communications connections</i>	31
Appendix G - Definitions	32

Superseded

Foreword

Introduction: This Metering Code of Practice ("Code") forms part of the Settlement Agreement for Scotland (the "Agreement"). In the event of inconsistency between the provisions of this Code and the other provisions of this Agreement, Clause 1.4(Hierarchy in this Agreement) shall apply.

Technical equivalent: This Code is technically equivalent to Code of Practice 2 Version 1.08 in England and Wales.

Purpose: This Code defines the minimum requirements for the Metering Equipment required for the measurement and recording of electricity transfers at Defined Metering Points where the rated circuit capacity does not exceed 100MVA.

Circuit capacity: For the purpose of this Code the rated circuit capacity in MVA shall be determined by the lowest rated primary plant (e.g. transformer rating, line rating, etc.) of the circuit. The Metering Equipment provision and accuracy requirements shall anticipate any future up-rating consistent with the installed primary plant. The primary plant maximum continuous ratings shall be used in this assessment.

Copies: Scottish Electricity Settlements Limited ("Scottish Settlements") shall retain copies of the Code in accordance with the provisions of this Agreement.

1. Scope

- 1.1 *Scope:* This Code states the practices that shall be employed, and the facilities that shall be provided for the measurement and recording of the quantities required for Allocation purposes on each circuit where the rated capacity does not exceed 100MVA.
- 1.2 *Extent:* This does not contain the calibration, testing and commissioning requirements for Metering Equipment used for Allocation purposes. These requirements are detailed in Metering Code of Practice S4 - "Metering Code of Practice for Calibration, Testing and Commissioning Requirements for Metering Equipment for Allocation Purposes".
- 1.3 *Derogations:* Derogations from the requirements of this Code may be sought in accordance with Part IX (Governance of this Agreement) or may exist under Schedule 7 (Derogations) of the Agreement and those Derogations which exist under Schedule 7 and are applicable to all Parties are listed in Appendix F.
- 1.4 *Responsibility:* Where responsibilities and obligations contained in this are expressed as being responsibilities and obligations of a Meter Operator, the Associated Responsible Party shall procure that any Meter Operator appointed by it pursuant to Clause 24.2 (Appointment of Meter Operators for Bulk Supply Points); Clause 39(Appointment of Supplier Agents) or Clause 54 (Generator Agents) complies with such responsibilities and obligations or may, if permitted to do so by the terms of this Agreement, perform such responsibilities and obligations itself.
- 1.5 *Nominated agent:* Where there is a reference to Scottish Settlements having a right or a duty to receive information or to provide a checking role under this Code that information may be received or that role may be performed by Scottish Settlements or any agent nominated by Scottish Settlements.

2. References

2.1 *References:* The following documents are also referred to in the text:-

BS EN 60687	Alternating-Current Static Watt Hour Meters for Active Energy (Classes 0.2S and 0.5S);
BS EN 60521	Class 0.5, 1 and 2 Alternating-Current Watt Hour Meters;
BS EN 61268	Alternating Current Static Var-Hour Meters for Reactive Energy (Classes 2 and 3);
BS 5685 Part 4	Specification for Class 3 Var-Hour Meters;
IEC Standard 44-3	Instrument Transformers - Combined Transformers;
IEC Standard 185	Current Transformers;
IEC Standard 186	Voltage Transformers;
BS EN 61107	Data Exchange for Meter Reading, Tariff and Load Control. Direct Local Exchange;
Metering Code of Practice S4	Metering Code of Practice for Calibration, Testing and Commissioning Requirements for Metering Equipment for Allocation Purposes;
Electricity Act 1989	Schedule 7 as amended from time to time;
Meter Operator Code of Practice	Schedule 5 to the Agreement between Meter Operators and Public Electricity

Suppliers governing arrangements for safety and technical competence; and

Standard Frequency and Time International Telecommunications
Signal Emission Union - RTF.460 (ISBN 92-61-05311-4).

3. Definitions

Definitions: Save as otherwise expressly provided herein, words and expressions used in this Code shall have the meanings attributed to them in Schedule 1 of the Agreement (Definitions) which for ease of reference are repeated in Appendix G.

4. Measurement Criteria

4.1 *Measured quantities and Demand Values:*

4.1.1 Measured quantities: For each separate circuit the following energy measurements are required:-

Import kWh *

Export kWh *

Import kvarh

Export kvarh

4.1.2 Demand Values: For each Demand Period for each circuit the following Demand Values shall be provided:-

Import kW *

Export kW *

Import kvar

Export kvar.

* Import and/or Export metering need only be installed where a Party requires this measurement to meet systems or plant conditions.

Where Import and/or Export metering is installed gross Import and Export Active Energy shall be recorded separately for Allocation. For multiple

circuit connections between Parties the configuration of the Metering Equipment shall be agreed in advance with Scottish Settlements.

4.2 *Accuracy requirements:*

4.2.1 Overall accuracy: The overall accuracy of the energy measurements at or referred to the Defined Metering Point shall at all times be within the limits of error as shown:

4.2.1.1 Active Energy

CONDITION	LIMIT OF ERRORS AT STATED SYSTEM POWER FACTOR	
	Power Factor	Limits of Error
Current expressed as a percentage of Rated Measuring Current		
120% to 10% inclusive	1	± 1.0%
Below 10% to 5%	1	± 1.5%
Below 5% to 1% *	1	± 2.5%
120% to 10% inclusive	0.5 lag and 0.8 lead	± 2.0%

* This requirement shall only apply where the energy transfers to be measured by the Import Meter and/or the Export Meter during normal operating conditions is such that the measured current will be below 5% of the Rated Measuring Current (excluding zero) for periods equivalent to 10% or greater per annum.

4.2.1.2 Reactive Energy

CONDITION	LIMIT OF ERRORS AT STATED SYSTEM POWER FACTOR	
Current expressed as a percentage of Rated Measuring Current	Power Factor	Limits of Error
120% to 10% inclusive	Zero	± 4.0%
120% to 20% inclusive	0.866 lag and 0.866 lead	± 5.0%

These limits of error for both Sections 4.2.1.1 and 4.2.1.2 shall apply at the reference conditions defined in the appropriate Meter specification.

Evidence to verify that these overall accuracy requirements are met shall be available for inspection by Scottish Settlements.

4.2.2 Compensation for measurement transformer error: To achieve the overall accuracy requirements it may be necessary to compensate Meters for the errors of the measurement transformers and the associated leads to the Meters. Values of the compensation shall be recorded and evidence to justify the compensation criteria, including wherever possible test certificates, shall be available for inspection by Scottish Settlements.

4.2.3 Compensation for power transformer and line losses: Where the Actual Metering Point and the Defined Metering Point do not coincide a Derogation shall be applied for and, where

necessary, compensation for power transformer and/or line losses shall be provided to meet the overall accuracy at the Defined Metering Point.

4.2.3.1 The compensation may be achieved in the Metering Equipment and in this event the applied values shall be recorded. Supporting evidence to justify the compensation criteria shall be available for inspection by Scottish Settlements.

4.2.3.2 Alternatively, the compensation may be applied in the software of the relevant Data Aggregation or System Data Provision Service system used for Allocation purposes. In this event the correction factors shall be passed to the appropriate agency and evidence to justify the compensation criteria shall be made available for inspection by Scottish Settlements.

5. Metering Equipment criteria

Classification: Although for clarity this Code identifies separate items of equipment, nothing in it prevents such items being combined to perform the same task provided the requirements of this Code are met.

Environment: Metering Equipment other than outdoor measurement transformers, shall be accommodated in a clean and dry environment.

For each circuit, other than one which is permanently disconnected, the voltage supply to any Meters, displays and Outstations shall be connected such that it is normally energised to facilitate reading of the Meter Register(s) and local and remote interrogation of the Outstation. (See Appendix E.)

Where an Outstation is storing data for more than one circuit and the Outstation power supply is from these circuits then a voltage selection relay scheme using each circuit involved shall be provided.

5.1 *Measurement transformers:* The terms "current transformer" and "voltage transformer" used below in Sections 5.1.1 and 5.1.2 do not preclude the use of other measuring techniques with a performance equal to that specified for such measurement transformers. For each circuit, current transformers ("CT") and voltage transformers ("VT") shall comply with the requirements set out in Sections 5.1.1 and 5.1.2. Additionally, where a combined unit measurement transformer (VT & CT) is provided the "Tests for Accuracy" as covered in clause 8 of IEC Standard 44-3 covering mutual influence effects shall be met.

5.1.1 *Current transformers:* A dedicated set of current transformers in accordance with IEC Standard 185 and with a minimum standard of accuracy to Class 0.2S (irrespective of the secondary current rating of the CTs) shall be provided for the sole use of Allocation metering of a circuit. No other burden shall be connected to this dedicated set of CTs. The main Meter shall always be connected to this dedicated set of CTs. The check Meter may also be connected to this dedicated set of CTs.

Alternatively the check Meter may be connected to another set of CTs which shall be in accordance with IEC Standard 185 and with a minimum standard of accuracy to Class 0.2S. Other burdens may be connected to this other set of CTs provided that Scottish Settlements is notified and the overall accuracy requirements in Section 4.2.1 are met and evidence of the additional burden is available for inspection by Scottish Settlements. The additional burden shall not be modified without prior notification to Scottish Settlements and evidence of the value of the modified additional burden shall be available for inspection by Scottish Settlements.

CT test certificates showing errors at the overall working burden or at burdens which enable the working burden errors to be calculated shall be available for inspection by Scottish Settlements.

The total burden on each CT shall not exceed the rated burden of such CT.

5.1.2 Voltage transformers: A dedicated voltage transformer secondary winding in accordance with IEC Standard 186 and with a minimum standard of accuracy to Class 0.5 shall be provided for the sole use of metering of a circuit for Allocation purposes. No other burden shall be connected to this dedicated winding. The main Meter shall always be connected to this dedicated winding. The check Meter may also be connected to this dedicated secondary winding. Alternatively the check Meter may be connected to another secondary winding which shall be in accordance with IEC Standard 186 and with a minimum standard of accuracy to Class 0.5. Other burdens may be connected to this other secondary winding provided that Scottish Settlements is notified and the overall accuracy requirements in Section 4.2.1 are met and evidence of the value of the additional burden is available for inspection by Scottish Settlements. The additional burden shall not be modified without prior notification to Scottish Settlements, and evidence of the value of the modified additional burden shall be available for inspection by Scottish Settlements.

A VT test certificate(s) showing errors at the overall working burden(s) or at burdens which enable the working burden errors to be calculated shall be available for inspection by Scottish Settlements.

The total burden on each secondary winding of a VT shall not exceed the rated burden of such secondary winding.

The VT supplies shall be fused as close as practicable to the VT, with a set of isolating links, suitably identified, provided locally to the Metering Equipment.

5.1.3 Monitoring of voltage transformers: Where a common mode fault, such as a VT fuse failure, could cause incorrect voltages on both the main Meters and check Meters a voltage monitoring relay shall be provided at or adjacent to the associated Meter panel. This monitoring facility's operating sensitivity shall enable detection of a voltage imbalance of 5% or more (expressed as a percentage of nominal voltage). The monitoring facility shall incorporate a time delay feature (e.g. 2-3 hours) before an alarm is activated so as to avoid spurious operation.

A spare channel on the Outstation or any other available means may be used to flag the alarm to the Data Collector.

With the agreement of Scottish Settlements the check metering data may be interrupted to provide a means of signalling this alarm.

5.1.4 Measurement transformers installed on existing circuits: Where circuits, other than those newly installed, are to be metered to this Code and where the installed measurement transformers do not comply with the Class accuracies specified in Sections 5.1.1 and 5.1.2 and, then such measurement transformers may be used providing the following requirements and those in Sections 4.2.1 and 5.1.3 are met:-

5.1.4.1 where subsequently a significant alteration to the primary plant (e.g. a switchgear change) is carried out, new measurement transformers as detailed in Sections 5.1.1 and 5.1.2, shall be provided; and

5.1.4.2 in all other respects the requirements of Sections 5.1.1 and 5.1.2 are met, except that where test certificates are not available other documentary evidence as referred to in Section 4.2.2 shall be available.

5.2 *Fusing and testing facilities:* Testing facilities shall be provided close by the Meters of each circuit which enable such Meters to be routinely tested and/or changed safely with the circuit energised. (See Appendix C.)

Separate fusing shall be provided locally for:-

- 5.2.1 the main Meters;
- 5.2.2 the check Meters;
- 5.2.3 any other Metering Equipment burden for Allocation purposes; and
- 5.2.4 any other non-Allocation metering burden.

Local fusing shall discriminate with the source fusing.

A typical arrangement is illustrated in Appendix C.

5.3 *Meters:* The Meters may be either static or induction disc types.

5.3.1 For each circuit main Meters and check Meters shall be supplied for the measurement of Active Energy. These Meters shall meet the requirements of either BS EN 60687 Class 0.5S or BS EN 60521 Class 0.5. Where the overall accuracy in the range "Below 5% to 1%" (as defined in Section 4.2.1) is required only Meters complying with BS EN 60687 Class 0.5S shall be used.

Meters provided for the metering of supplies to Customers of Active Energy shall be in accordance with Schedule 7 of the Act.

5.3.2 For each circuit only main Meters need be supplied for the measurement of Reactive Energy. The Meters for the measurement of Reactive Energy shall meet the requirements of either BS EN 61268 Class 3.0 or BS 5685 Part 4.

All Meters supplied via measurement transformers shall be set to the actual primary and secondary ratings of the measurement transformers and the ratios displayed as follows:-

5.3.2.1 for Meters separate from the display and/or Outstation, the ratios shall be recorded on the nameplate of the Meter;

5.3.2.2 for static Meters combined with the display and/or Outstation, the ratios shall be displayed and downloaded during the interrogation process. In addition, the compensation factor that has been applied for measurement transformer errors and/or system losses, where this is a constant factor applied at security level 3, shall be similarly displayed and downloaded.

5.3.3 Meters for the measurement of Active Energy shall be configured such that the number of measuring elements is equal to, or one less than the number of primary system conductors. These include the neutral conductor, and/or the earth conductor where system configurations enable, the flow of zero sequence energy.

Meter Registers: All Meters shall include a non-volatile Meter Register of cumulative energy for each measured quantity which shall not roll-over more than once within the normal Meter reading cycle.

Outputs to separate Outstations: Meters which provide data to separate Outstations shall for this purpose provide an output per measured quantity.

Displays: For Meters using electronic display due account shall be taken of the obligation of the Responsible Party to obtain Meter readings.

Labelling: All Meters shall be labelled or otherwise be readily identifiable with respect to their associated circuits in accordance with Appendix B.

5.4 *Displays and facilities for Responsible Party information:*

5.4.1 Displays

5.4.1.1 Mandatory displays

Metering Equipment shall display the following primary information (not necessarily simultaneously):-

- (i) measured quantities as per Section 4.1.1;
- (ii) current time ("UTC") and date;
- (iii) the CT and/or VT ratios that the Meter has been programmed to, where appropriate (see Section 5.3); and
- (iv) the compensation factor that has been applied for measurement transformer errors and/or system losses, where this is a constant factor applied a security level 3 (i.e. where the Meter is combined with the display and/or Outstation).

5.4.1.2 Display capabilities

The Metering Equipment shall be capable of enabling the display of the following information, as specified by the Responsible Party:-

- (i) Maximum Demand ("MD") for kW per programmable charging period, ie monthly or statistical review period;
- (ii) MD for kVA per programmable charging period, ie monthly or statistical review period;

- (iii) twice the kWh advance since the commencement of a current Demand Period, (i.e. "kW rising demand");
- (iv) twice the kVAh advance since the commencement of a current Demand Period, (i.e. "kVA rising demand");
- (v) cumulative MD;
- (vi) number of MD resets;
- (vii) multi-rate display sequence as specified by the Responsible Party, with a minimum of 8 rates selectable over the calendar year; and
- (viii) indication of reverse running for Active Energy, where appropriate.

MD shall be resettable at midnight of the last day of a charging period and for part chargeable period demands. If a manual reset button is provided then this shall be sealable.

5.4.2 Facilities for Responsible Party use:

5.4.2.1 The Metering Equipment shall be capable of providing the following information locally to the Responsible Party configured to their requirements taking account of the measured quantities (see Section 4.1.1):-

- (i) impulsing for Import kWh, Export kWh, Import kvarh, Export kvarh and kVAh - all to be voltage free contacts with a pulse rate at full load of between 0.1 and 2 pulses per second with a nominal duration of 80mS per pulse; and

- (ii) a 30 minute reset pulse, within a tolerance of +/- 0.1% of the Demand Period from voltage free contacts with a minimum duration of 0.5 second and a maximum duration of 10 seconds.

5.5 *Outstation:* An Outstation system shall be provided which transfers data to and receives data from any Settlement Instation.

Where a single separate Outstation is provided for storing data for more than one circuit, the maximum aggregated capacity shall be 100 MVA.

Where more than one separate Outstation is provided the main Meter and check Meter data shall be stored in different Outstations.

The Outstation data shall be to a format and protocol approved by Scottish Settlements.

The Outstation shall facilitate the metering data to be read by any Settlement Instation provided the requirements of Section 7 of this Code are satisfied.

For the purpose of transferring stored metering data from the Outstation to the Settlement Instation a unique Outstation identification code shall be provided.

Normally metering data will be collected by the Settlement Instation by a daily interrogation, but repeat collections of metering data shall be possible throughout the Outstation data storage period.

If not integral, the Outstation system supply shall either be from a secure supply, or from a measurement VT with separate fusing for each Outstation.

Where a separate modem associated with the Outstation system is used, then it shall be provided with a separately fused supply either from a secure supply or from a measurement VT (See Section 5). Alternatively, line or battery powered modem types may be used.

5.5.1 *Data storage:* Data storage facilities for metering data shall be provided as follows:-

- 5.5.1.1 each Demand Value shall be identifiable to its respective date and time;
- 5.5.1.2 a storage capacity of 48 periods per day for a minimum of 20 days for all Demand Values; (See Section 4.1.2)
- 5.5.1.3 the stored Demand Values shall be integer values of kW or kVAr, and have a resolution of better than $\pm 0.1\%$ (at full load);
- 5.5.1.4 the accuracy of the energy values derived from Demand Values shall be within $\pm 0.1\%$ (at full load) of the amount of energy measured by the associated Meter;
- 5.5.1.5 the value of any energy measured in a Demand Period but not stored in that Demand Period shall be carried forward to the next Demand Period;
- 5.5.1.6 where a separate Outstation is used, cumulative register values shall be provided in the Outstation which can be set to match and increment with the Meter Registers;
- 5.5.1.7 in the event of an Outstation supply failure, the Outstation shall protect all data stored up to the time of the failure, and maintain the time accuracy in accordance with Section 5.5.2;
- 5.5.1.8 partial Demand Values, those in which an Outstation supply failure and/or restoration occurs, and zero Demand Values associated with an Outstation supply failure, shall be marked so that the Settlement Instation can identify them;
- 5.5.1.9 to cater for continuous supply failures, the clock, calendar and all data shall be supported

for a period of 20 days without an external supply connected;

5.5.1.10 any "read" operation shall not delete or alter any stored metered data; and

5.5.1.11 an Outstation shall provide all of the metered data stored from the commencement of any specified date upon request by the Settlement Instation.

5.5.2 Time keeping: The Outstation time shall be set to Co-ordinated Universal Time (UTC). No switching between UTC and British Summer Time (BST) shall occur for data storage requirements for Allocation purposes.

5.5.2.1 Time synchronisation of the Outstation may be performed remotely by the Settlement Instation as part of the normal interrogation process or locally by an Interrogation Unit.

5.5.2.2 When time synchronisation occurs the relevant period(s) shall be marked with an alarm indication, as outlined in Section 5.5.3.

5.5.2.3 The overall limits of error for the time keeping allowing for a failure to communicate with the Outstation for a period of 20 days shall be:-

- (i) the completion of each Demand Period shall be at a time which is within ± 20 seconds of UTC; and
- (ii) the duration of each Demand Period shall be within $\pm 0.1\%$, except where time synchronisation has occurred in a Demand Period.

5.5.3 Monitoring facilities: Monitoring facilities shall be provided for each of the following conditions and shall be reported, as separate alarm indications tagged to the relevant Demand

Period(s), via on-line communications and the local Interrogation Unit:-

- 5.5.3.1 Metering Equipment resets caused by other than a supply failure (where fitted);
- 5.5.3.2 battery monitoring (where battery fitted);
- 5.5.3.3 interrogation port access which changes time and/or date;
- 5.5.3.4 interrogation port access which changes data other than time or date; and
- 5.5.3.5 where different from Section 5.5.3.4, Demand Period(s) which have been truncated or extended by a time synchronisation; and
- 5.5.3.6 reverse running if fitted.

All of the above conditions shall be reported as, at minimum, a common alarm indication via the remote interrogation facility.

In addition to Section 5.5.3.1, detected errors in Metering Equipment functionality should be recorded as an event alarm with date and time. Any alarm indication shall not be cancelled or deleted by the interrogation process and shall be retained with the data until overwritten. The alarm shall reset automatically when the abnormal condition has been cleared.

5.6 *Communications:* Outstations shall accommodate both local and remote interrogation facilities from separate ports. To prevent unauthorised access to the data in the Metering Equipment a security scheme, as defined below and in Appendix D, shall be incorporated for both local and remote access separate security levels shall be provided for the following activities:-

5.6.1 Level 1 - password to enable read only of the following metering data, which shall be transferable on request during the interrogation process:-

- 5.6.1.1 Outstation ID;

- 5.6.1.2 Demand Values as defined in Section 4.1.2 for main Meters and check Meters;
- 5.6.1.3 cumulative measured quantities as defined in Section 4.1.1 for main Meters and check Meters;
- 5.6.1.4 Maximum Demand (MD) for kW or kVA per programmable charging period ie monthly, statistical review period;
- 5.6.1.5 multi-rate cumulative Active Energy as specified by the Responsible Party;
- 5.6.1.6 the measurement transformer ratios, where appropriate (see Section 5.3);
- 5.6.1.7 the measurement transformer error correction factor and/or system loss factor, where this is a constant factor applied to the entire dynamic range of the Meter and the Meter is combined with the display and/or Outstation;
- 5.6.1.8 alarm indications; and
- 5.6.1.9 Outstation time and date.
- 5.6.2 Level 2 - password for:-
 - 5.6.2.1 corrections to the time and/or date; and
 - 5.6.2.2 resetting of the MD.
- 5.6.3 Level 3 - password for programming of:-
 - 5.6.3.1 the display and facilities as defined in Section 5.4;
 - 5.6.3.2 the measurement transformer ratios, as appropriate (see Section 5.3);
 - 5.6.3.3 the measurement transformer error correction and/or system loss factor where this is a constant factor applied to the entire dynamic range of the Meter and the Meter is combined with the display and/or Outstation; and

5.6.3.4 the passwords for levels 1, 2 and 3.

In addition, it shall be possible to read additional information within the Metering Equipment to enable the programmed information to be confirmed.

5.6.4 Level 4 - password or removal of Metering Equipment cover(s) necessitating the breaking of a seal for:-

5.6.4.1 calibration of the Metering Equipment;

5.6.4.2 setting the measurement transformer ratios, as appropriate;

5.6.4.3 programming the measurement transformer error correction factor and/or system loss factor where this is other than a single factor; and

5.6.4.4 programming the level 3 password and the level 4 password, if appropriate.

In addition to the functions specified for each level it shall be feasible to undertake the functions at the preceding level(s) e.g. at level 3 it shall also be possible to carry out the functions specified at levels 1 and 2. This need not apply at level 4 when access is obtained via removing the cover.

Different passwords shall be utilised for each level, which shall only be circulated in accordance with the relevant Market Procedure(s), including MP-502.

5.7 *Local interrogation:* An interrogation port shall be provided for each Outstation which preferably shall be an optical port to BS EN 61107, and with a serial protocol such as BS EN 61107.

5.8 *Remote interrogation:* Remote interrogation facilities shall always be provided with error checking of the communications between the Outstation system and the Settlement Instation. It shall not be possible to disconnect the remote communication connection to/from the Outstation without the breaking of an appropriate seal (see Section 5.9).

5.8.1 Interrogation of an Outstation shall be possible using one of the following media:-

- 5.8.1.1 switched telephone networks e.g. PSTN or CTN;
- 5.8.1.2 public data networks e.g. PSN;
- 5.8.1.3 radio data networks e.g. Paknet or any equivalent;
- 5.8.1.4 customer's own network;
- 5.8.1.5 mains signalling / power line carrier;
- 5.8.1.6 low power radio;
- 5.8.1.7 Satellite; or
- 5.8.1.8 Cable TV.

In addition any further media may be used as approved by the Responsible Party.

5.8.2 The actual media employed shall be in accordance with the requirements of the Responsible Party.

5.8.3 The data shall be to a format and protocol approved by Scottish Settlements.

5.9 *Appropriate seals:* All Metering Equipment shall be capable of being sealed in accordance with Appendix 8 and 9 of the Meter Operator Code of Practice.

6. Associated Facilities

6.1 *Interrogation Unit:* The Outstation shall be capable of being interrogated by an Interrogation Unit. The Interrogation Unit may be used for programming, commissioning, maintenance/fault finding and when necessary the retrieval of stored metering data. The data retrieved by the Interrogation Unit shall be compatible with the Settlement Installation. The Interrogation Unit shall have a built-in security system, such as a password so that the Interrogation Unit becomes inoperative and non-interrogatable if it is lost, stolen, etc.. The password can be applied at power-on of the device and/or on entry to the Interrogation Unit software application.

6.2 *Additional features:* Additional features may be incorporated within or associated with the Metering Equipment provided that these shall not interfere with or endanger the operation of the Allocation process.

7. Access to Data

7.1 *Access:* Access to metering data shall be in accordance with the provisions of this Agreement including without limitation Schedule 5, Section 13 and the Market Procedures. Such access must not interfere with or endanger the security of the data or the collection process for Allocation purposes.

Superseded

Appendix A

Defined Metering Points

1.1 *Defined Metering Point:* For transfers of electricity between the following parties the Defined Metering Point ("DMP") shall be at one of the following locations for transfers between:-

- 1.1.1 a Host Company's Transmission System and a Distribution System where no other Party(s) or Distributor(s) are connected to the busbar, the DMP shall be at the lower voltage side of the grid connected transformer;
- 1.1.2 a Host Company's Transmission System and a Distribution System where other Party(s) or Distributor(s) are connected to the busbar, the DMP shall be at the circuit connections to that Distribution System;
- 1.1.3 the Distribution Businesses not including a connection to the Transmission System of either Host Company, the DMP shall be at the point of connection of the Distribution System;
- 1.1.4 a Host Company's Transmission System and Grid-connected Power Stations, the DMP shall be at the high voltage side of the generator transformers and station transformer(s);
- 1.1.5 a Distribution System and Embedded Generation Sites, the DMP shall be at the point(s) of connection of the Generation Sites to the Distribution System;
- 1.1.6 a Distribution System and an Embedded Customer Site, the DMP shall be at the point of connection to the Distribution System;
- 1.1.7 a Distribution System and a Grid connected Power Station, the DMP shall be at the point of connection to the Distribution System; and
- 1.1.8 a Host Company's Transmission System and a Grid-connected Customer or Composite Site, the DMP shall be at the point of connection to the Transmission System.

Appendix B

Labelling of Meters for Import and Export

1.1 *Standard method:* A standard method of labelling Meters, test blocks, etc. is necessary and based on the definitions for Import and Export the required labelling shall be as follows:-

1.1.1 Active Energy:-

Meters or Meter Registers shall be labelled "Import" or "Export" according to "Figure 1". This convention is based on "Import" and "Export" being from the viewpoint of the Responsible Party.

1.1.2 Reactive Energy:-

within the context of this Code the relationship between Active Energy and Reactive Energy can best be established by means of the power factor. The following table gives the relationship:-

Flow of Active Energy	Power Factor	Flow of Reactive Energy
Import	Lagging	Import
Import	Leading	Export
Import	Unity	Zero
Export	Lagging	Export
Export	Leading	Import
Export	Unity	Zero

Meters or Meter Registers for registering Import Reactive Energy should be labelled "Import" and those for registering Export Reactive Energy should be labelled "Export".

1.1.3 Import and Export Active Energy flows from the viewpoint of the Responsible Party.

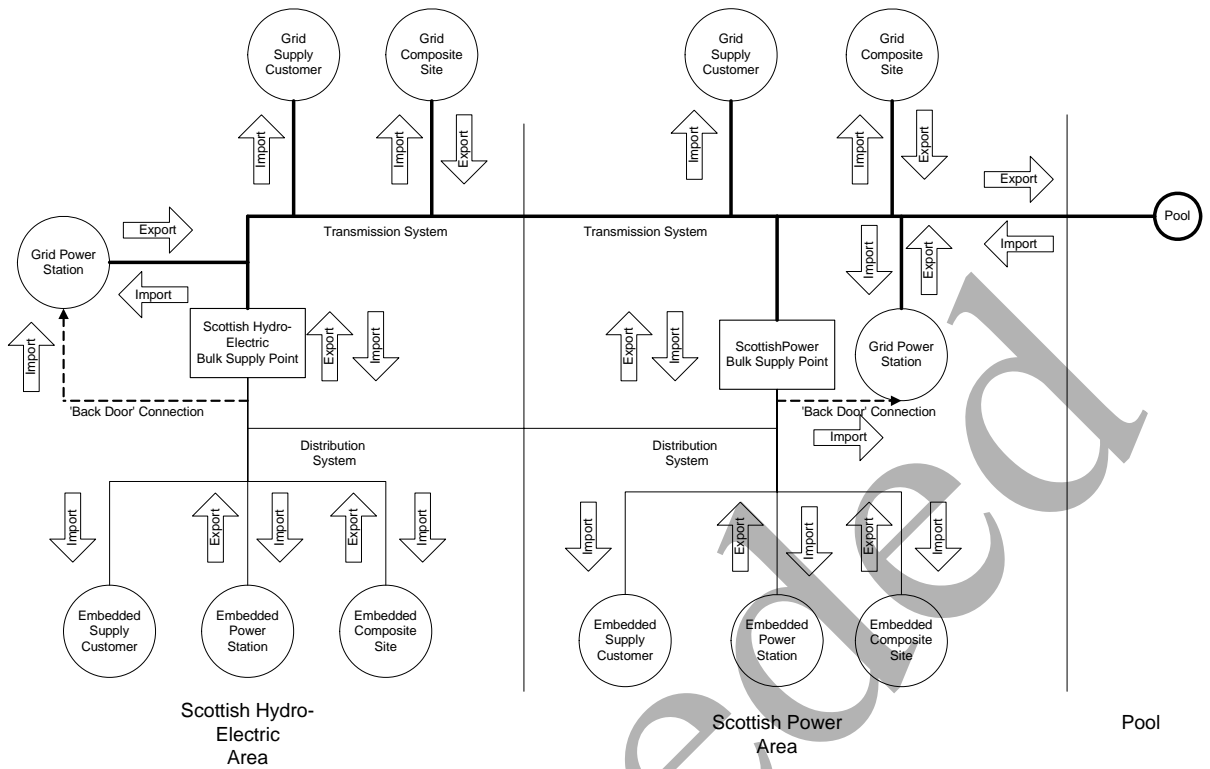
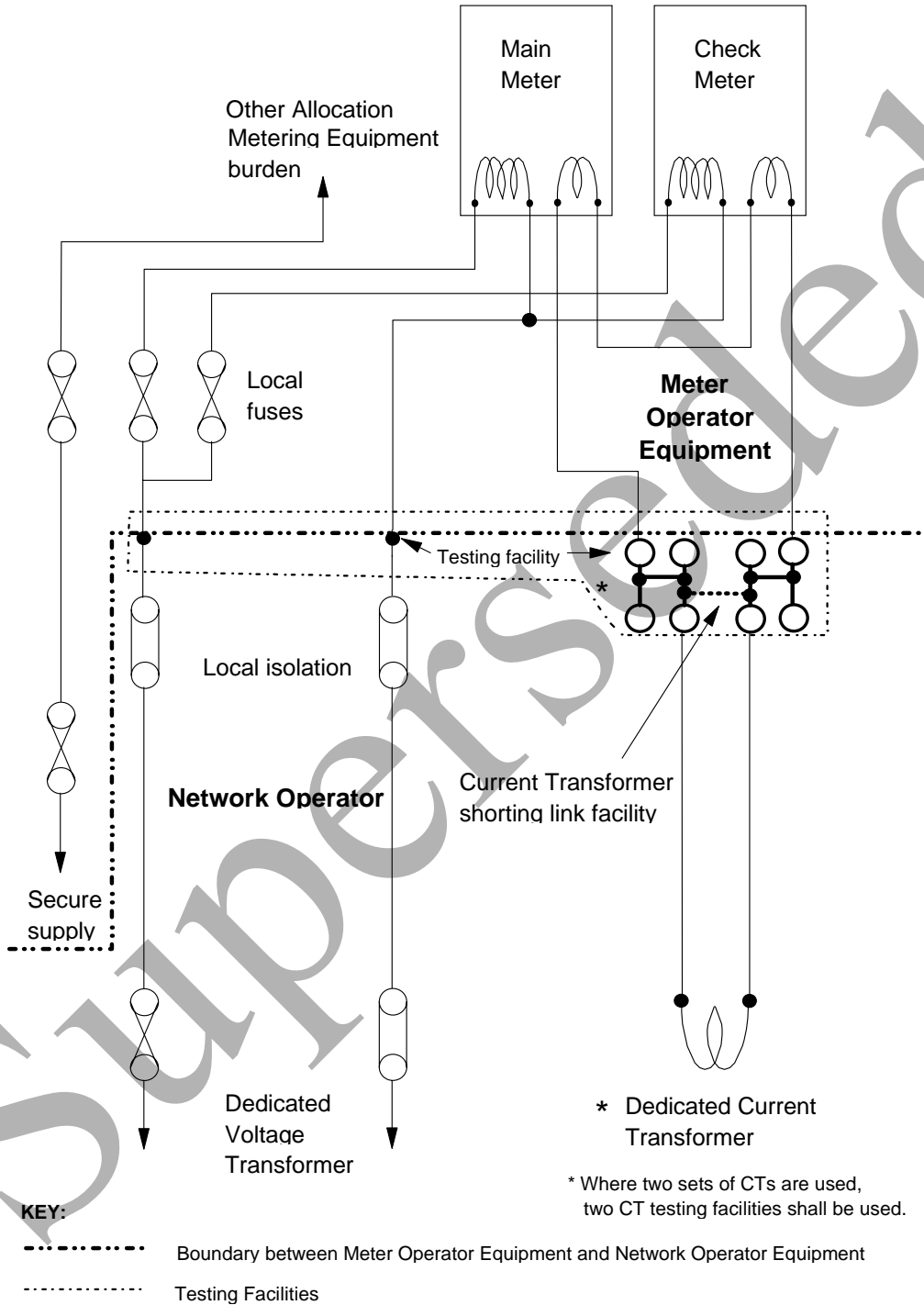

Figure 1

Appendix C

"Typical Testing Facilities and Fusing Arrangements"



Appendix D

Responsible Party Passwords

1. The passwords specified in Section 5.6 shall be subject to the following additional requirements:-
2. The communications protocol employed shall ensure that the password offered determines the level of access to the data within the Metering Equipment.
3. A counter logging the number of illegal attempts (i.e. password comparison failures) to access Metering Equipment via the local and remote ports shall be incorporated into the log-on process. This counter shall reset to zero at every hour change (i.e. 0100, 0200, etc.).
4. If the counter reaches 7, then access is prohibited at all levels until the counter resets at the next hour change.

Appendix E

Options for ensuring Meters and Displays can be read and remotely interrogated

This Appendix sets out the options for complying with the requirements set out in Section 5 for certain types of supply where the voltage supply to the Metering Equipment would not normally be maintained for significant periods, e.g. those used for standby and those where the Customer's restricted period load is controlled by the main incoming switchgear.

1. Connection of Metering Equipment to the live side of the supply
For new supplies the most practical solution would be to arrange for the Metering Equipment to be connected to the incoming side of the main switchgear so that it is normally energised even when the switchgear is open.
2. Install separate Meters and displays/Outstations
Installation of separate Meters and displays/Outstations would enable the latter to be connected to a normally energised supply. This would facilitate local and remote interrogation and reading on a routine basis. The Meters would need to be provided with a permanent Meter Register to meet the requirements of Section 5.3.
3. Combined Meters, displays and Outstations with separate auxiliary supply facilities
Integrated products could be utilised which have separate input terminals to energise the data storage and display functions which could be connected to a normally energised supply, whilst the voltage supply to the Meter is from the relevant circuit.
4. Combined Meters, displays and Outstations supplied via a voltage relay selection scheme

With this option the integrated equipment would be connected to an appropriate single phase voltage supply via a voltage relay selection scheme such that whilst this circuit was de-energised it would receive its voltage supply only, from the adjacent circuit. However, when this circuit was energised

it would be fed with both voltage and current from the measured circuit.
This arrangement is shown in Figure 2 overleaf and is only suitable for
use with CT operated Metering Systems.

Superseded

Figure 2

Schematic diagram showing a typical voltage selection relay scheme on HV or LV, normally De-energised supplies, to enable Meter reading (CT only)

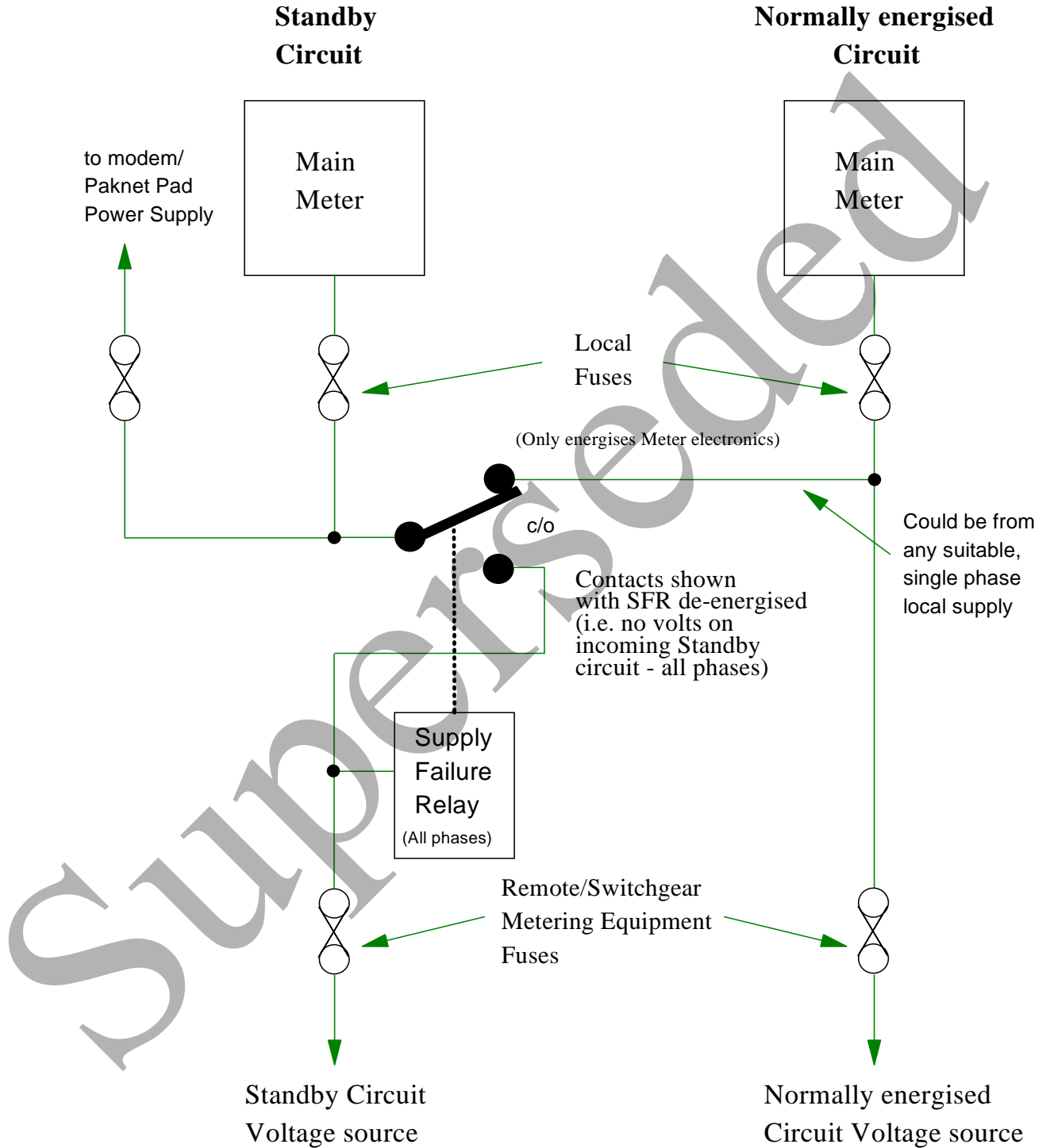

Appendix F

Generic Derogations

The following generic Derogations from the requirements of this Code are applicable to all Parties and Distributors:-

1.1 *summation CTs:*

where existing metering installations utilise summation CTs these installations do not need to be modified to comply with this Code; or

1.2 *position of metering:*

where the Actual Metering Point and the Defined Metering Points do not coincide at existing installations no specific Derogation application is required; or

1.3 *passwords:*

existing Metering Equipment that does not conform with the Password requirements specified within this Code does not need to be upgraded; and

1.4 *sealing of communications connections:*

where communications connections are not capable of being sealed and have not been sealed in accordance with this Code the sealing requirements will be waived and modifications shall be completed to enable such requirements to be met by 01/04 2000,

in each of the cases in Sections 1.1 to 1.3 above unless and until the Metering Equipment is replaced or there has been a material change as described in Schedule 5, Section 4.3.2.

Appendix G

Definitions

"Accredited Laboratory"	means the National Physical Laboratory (NPL), or a calibration laboratory that has been accredited by the National Measurement Accreditation Service (NAMAS), or an international laboratory recognised by NPL for the measurement required, or any other laboratory approved by the Director;
"Act"	means the Electricity Act 1989;
"Active Energy"	means the electrical energy produced, flowing or supplied by an electric circuit during a time interval, being the integral with respect to time of the instantaneous power, measured in units of watt-hours (Wh) and standard multiples thereof, that is 1,000 Wh = 1 kilowatt-hour (kWh) 1,000 kWh = 1 megawatt-hour (MWh) 1,000 MWh = 1 gigawatt-hour (GWh) 1,000 GWh = 1 terawatt-hour (TWh);
"Actual Metering Point"	means the physical location at which energy is metered;
"Agent"	means any person acting on behalf of a principal in performance of obligations incumbent upon a Party or Distributor in terms of this Agreement;
"Agreement"	means this Agreement (including the Recitals and the Schedules) as amended, varied, supplemented, modified or suspended from time to time in accordance with the terms hereof;
"Allocation"	means the operation of the Central Allocation

	System;
"Amps"	means amperes;
"Associated Responsible Party"	means the Responsible Party which appointed the relevant Agent;
"Balancing and Settlement Code"	means the Agreement of that name between NGC and others to be entered into or entered into in part implement of the reforms of the Electricity Market in England and Wales permitting physical bi-lateral contracts to be entered into between Generators and Suppliers;
"Balancing and Settlement Code Company"	means Elexon Limited (registered number 03782949) a company registered in England and Wales having its registered office at 3 rd Floor, 15 Marylebone Road, London NW1 5JD;
"Bulk Supply Point" or "BSP"	means a point of supply from a Transmission System to a:- <ul style="list-style-type: none"> (i) Distribution System; or (ii) Exempt Distribution System; or (iii) Grid-connected Composite Site; or (iv) Grid-connected Customer Site;
"Certification Regulations "	means S1792 The Meters (Certification) Regulations 1990;
"Code of Practice"	means each of the codes of practice in force in England and Wales in relation to any Metering Equipment or any part or class thereof;
"Composite Site"	means a Grid-connected Generation Site or Embedded Generation Site at which a Generator Party or Non Trading Generator:- <ul style="list-style-type: none"> (i) exports Active Energy to a Distribution System or a Transmission System; and (ii) imports Active Energy from a Distribution System or a Transmission

	System for purposes other than the generation of electrical energy;
"Co-ordinated Universal Time" or "UTC"	has the same meaning as in the document Standard Frequency and Time Signal Emission, International Telecommunication Union (CRTF.4609ISBN92-61-05311-4);
"Cumulative Reading"	means a record of the value indicated by the Cumulative Register at a given point in time;
"Customer"	means any person supplied or requiring to be supplied with electricity at premises within the BSP Group of Scottish Hydro-Electric or ScottishPower other than a person supplied or requiring to be supplied with electricity at a Power Station (save where such supply is to a Grid-connected Power Station connected to the Transmission System of one Host Company but with an auxiliary supply connected to a Distribution System in the other Host Company's BSP Group) or any person transferring electricity to or from ScottishPower's or Scottish Hydro-Electric's BSP Group (as appropriate) across an interconnector, in its capacity as such;
"Data Aggregation"	means the process of aggregating consumption figures received from Data Collectors;
"Data Collection"	means the retrieval, validation and processing of metering data;
"Data Collector"	means an Accredited person appointed by a Supplier, Generator Party or Host Company pursuant to Clause 25.1, Clause 39.1 or Clause 54.1, as the case may be, for the purposes of this Agreement;
"Defined Metering Point" or	means the physical location at which the overall

"DMP"	accuracy requirements are to be met, such physical location and accuracy requirements being as stated in the Metering Codes of Practice;
"Demand Period"	means the period over which Active Energy, Reactive Energy or Apparent Energy are integrated to produce Demand Values for Allocation purposes and unless the context otherwise requires, each Demand Period shall be of thirty (30) minutes duration one of which will finish at 2400 hours;
"Demand Value"	means, expressed in kW, kvar, kVA, twice the value of kWh, kvarh or kVAh recorded during any Demand Period, the Demand Values are Half Hour Demands identified by the end of the Demand Period;
"Derogation"	means a derogation given in terms of Clause 93 (Derogations);
"Distribution Licence"	means a Distribution Licence granted, (or to be treated as granted) under Section 6(1)(c) of the Act;
"Distribution System"	means a system for the distribution of electrical energy as defined in the Distribution Licence of the ScottishPower Distribution Undertaking, the Scottish and Southern Energy Distribution Undertaking or any Distributor;
"Embedded"	means solely connected to a Distribution System or an Exempt Distribution System, such connection being either a direct connection or a connection via a busbar of another User;

"Export" means:-

- (i) a flow of Active Energy from a Generation Site onto the Distribution System or Transmission System; or
- (ii) a flow of Active Energy from a BSP onto the Transmission System; or
- (iii) a flow of Active Energy out of Scotland despatched by ScottishPower's Grid Control Centre

and "Exported" shall be construed accordingly;

"Generation Site" means any Grid-connected or Embedded Power Station or any Grid-connected or Embedded Composite Site as the case may be;

"Generator Agent" means any Meter Operator or Data Collector appointed by a Generator Party pursuant to Clause 54.1 (Appointment of Generation Agents);

"Grid-Connected" means directly connected to a Transmission System;

"GWh" means gigawatt hours;

"Identifier" or "Id" means a unique number and/or letter or, as the case may be, a unique combination of numbers and/or letters;

"Import" means:-

- (i) a flow of Active Energy to a Generation Site from the Distribution System or Transmission System; or
- (ii) a flow of Active Energy to a BSP from the Transmission System; or
- (iii) a flow of Active Energy into Scotland despatched by ScottishPower's Grid Control Centre

and "Imported" shall be construed accordingly;

"Interrogation Unit"	means a portable computer used by Data Collectors to extract and store information from the Outstations;
"kVA"	means kilovoltamperes;
"kVAh"	means kilovoltampere hours;
"kvar"	means kilovoltamperes reactive;
"kvarh"	means kilovoltamperes reactive hours;
"kW"	means kilowatts;
"kWh"	means kilowatt hours;
"Market Auditor"	means that person or persons appointed by Scottish Settlements to audit the operation of the market pursuant to Schedule 6 (Role of the Market Auditor);
"Market Procedure"	means each of the market procedures set out in Schedules 14 (Market Procedures for General Allocation) to 18 (Market Procedure for Accreditation and Certification) as amended, varied, supplemented, modified or suspended from time to time in accordance with the terms of this Agreement;
"Maximum Demand"	means the greatest of the Demand Values recorded during a given Meter Advance Period by Metering Equipment capable of recording Demand Values in each of the Half Hours of such charging period as may be identified by a Responsible Party;
"Meter"	means a device for measuring Active Energy and/or Reactive Energy;
"Meter Operator"	means a person Accredited to install, commission, maintain and energise Metering Equipment and "Meter Operation" shall be construed accordingly;

"Meter Operator Code of Practice" means Schedule 5 to the Agreement between Meter Operators and Distribution Businesses governing arrangements for safety and technical competence;

"Meter Register" means a physical device for measuring Active Energy or Reactive Energy;

"Metering Code of Practice" means each of the Scottish codes of practice relating to metering contained in Schedule 19 (Metering Codes of Practice) as amended, varied, supplemented, modified or suspended from time to time in accordance with the terms of this Agreement;

"Metering Equipment" means Meters and, where relevant, measurement transformers (voltage, current or combination units) metering protection equipment including alarms, circuitry, their associated communications equipment and Outstations, and wiring which are part of the Active Energy and/or Reactive Energy measuring and transmitting equipment for Allocation under this Agreement;

"Metering Point" means the point, determined according to the principles and guidance given at Schedule 9 to the Master Registration Agreement at which a supply (import) from a Distribution System and/or a Transmission System:-

- (i) is or is intended to be measured; or
- (ii) where Metering Equipment has been removed, was or was intended to be measured; or
- (iii) in the case of an Unmetered Supply, is deemed to be measured under the relevant Market Procedure(s) including MP-520,

where in each case such measurement is for the purposes of ascertaining the volumes allocated to that Supplier under this Agreement;

"Metering System"

means:-

(i) in the case of a metering system at a Bulk Supply Point, Power Station, or Composite Site (but always excluding metering systems at a Composite Site which comprise an Import Register and no Export Register), physically distinct and related Commissioned Metering Equipment at or relating to a Site which measures a trade in Active and/or Reactive Energy where the Active Energy is allocated in accordance with the Rules;

or

(ii) in the case of any other metering system and, where the context requires, metering systems at Composite Sites comprising a Settlement Register, a Metering Point;

"MVA"

means megavoltamperes;

"MW"

means Megawatts;

"MWh"

means Megawatt hours;

"Outstation"

means equipment which receives and stores data from a Meter for the purpose, *inter alia*, of transfer of that metering data to a Data Collector and which may perform some processing before such transfer. This equipment may be in one or more separate units or may be integral with the Meter;

"Party"

means each person for the time being party to this Agreement whether as a Founder Signatory or

	pursuant to an Accession Agreement and shall include any successor(s) in title to or permitted assignee(s) of such person, but always excluding a Non Trading Generator and a Distributor unless expressly otherwise provided;
"Performance Assurance and Accreditation Panel"	means the body established pursuant to Clause 84.1;
"Pool"	means the electricity pool of England and Wales set up under the Pooling and Settlement Agreement as now succeeded by the trading arrangements established pursuant to the Balancing and Settlement Code;
"Power Station"	means an installation comprising one or more generating units (even where sited separately) (other than a Composite Site), owned and/or controlled by the same Generator Party or Non Trading Generator which may reasonably be considered as being managed as one power station;
"Public Electricity Supplier" or "PES"	means the ScottishPower Distribution Undertaking or the ScottishPower Supply Undertaking or the Scottish and Southern Energy Distribution Undertaking or the Scottish and Southern Energy Supply Undertaking as the case may be as specified in Schedule 3A (ScottishPower Transfer Scheme) or Schedule 3B (Scottish and Southern Energy Transfer Scheme);
"Rated Measurement Current"	means the rated primary current of the current transformers in primary plant used for the purpose of measurement;
"Reactive Energy"	means the integral with respect to time of the Reactive Power;

"Reasonable and Prudent Operator"	means a person exercising that degree of skill, diligence, prudence and foresight which would reasonably and ordinarily be expected from a skilled and experienced operator engaged in the same type of undertaking under the same or similar circumstances;
"Reconciliation Run"	means any second or subsequent run of the Central Allocation System carried out by the Operating Agent for a Trading Day;
"Reference Standard"	means a standard whose measurement traceability to National Standards has been verified either at an Accredited Laboratory or is directly maintained by radio communication;
"Reference Temperature"	means a stated temperature for any apparatus at which that apparatus has a known specification. If no temperature is stated the Reference Temperature is 23°C;
"Responsible Party"	means:- <ul style="list-style-type: none"> (i) a Supplier in relation to a Metering System which is registered to that Supplier in the relevant PES Registration Service (and for the avoidance of doubt shall include any Metering System at any Grid-connected Customer Site, or Grid-connected Composite Site, so registered); <li style="padding-left: 2em;">or (ii) each Transmission Business in relation to a Metering System at a Bulk Supply Point which is registered in the relevant Bulk Supply Point Registration Service (which, for the avoidance of doubt, shall not include any Metering System at a Grid-

connected Customer Site or at a Grid-connected Composite Site); or

- (iii) a Generator Party in relation to a Metering System at a Registrable Generation Site which is registered to that Generator Party in the relevant Generation Registration Service (with the exception of any Metering System at such Registrable Generation Site which is a Composite Site and which comprises an Import Register or Import Registers), or a Metering System comprising a Registrable Import Register registered to it in the relevant Grid-connected Power Station (Import Registers) Registration Service;

"Scottish Company" means Scottish Hydro-Electric or ScottishPower, as appropriate and Scottish Companies means both of them;

"ScottishPower Distribution Undertaking" shall have the meaning given to the phrase "Distribution Undertaking" in the ScottishPower Transfer Scheme;

"ScottishPower Supply Undertaking" shall have the meaning given to the phrase "Supply Undertaking" in the ScottishPower Transfer Scheme;

"ScottishPower Transmission Undertaking" shall have the meaning given to the phrase "Transmission Undertaking" in the ScottishPower Transfer Scheme;

"Scottish and Southern Energy Distribution Undertaking" shall have the meaning given to the phrase "Distribution Undertaking" in the Scottish and Southern Energy Transfer Scheme;

"Scottish and Southern Energy" shall have the meaning given to the phrase

"Supply Undertaking"	"Supply Undertaking" in the Scottish and Southern Energy Transfer Scheme;
"Scottish and Southern Energy Transmission Undertaking"	shall have the meaning given to the phrase "Transmission Undertaking" in the Scottish and Southern Energy Transfer Scheme;
"Scottish Settlements"	means Scottish Electricity Settlements Limited (registered number SC 169212) a company registered in Scotland having its registered office at Delta House, 50 West Nile Street, Glasgow, G1 2NQ or such other person as is appointed as a successor to Scottish Electricity Settlements Limited in terms of Clause 13 (Appointment of successor to Scottish Settlements);
"Settlement Date"	means the calendar date of a specific Settlement Day;
"Settlement Day" or "Trading Day"	means the period beginning on the spot time of 00.00 and ending with, but not including, the spot time of 24.00, during which Active Energy is traded at any time from and after the Effective Trading Date for a BSP Group;
"Settlement Instation"	means a computer based system which collects or receives data on a routine basis from selected Outstation systems on behalf of any Party, Distributor or their Agents;
"Site"	means:- <ul style="list-style-type: none"> (i) a Transmission System Entry Point or Exit Point; or (ii) a Distribution System Entry Point or Exit Point or a Bulk Supply Point; (iii) the point of connection of an Exempt Distribution System or a Customer to a Distribution System or a Transmission

	System; and
	(iv) the point of connection of two Distribution Systems;
"Standard(s)"	means any of the following: Reference Standards; AC/DC Transfer Standards; AC Transfer Standards; or Working Standards, as the context so requires;
"Supplier"	means a Party which:- <ul style="list-style-type: none"> (i) is a Founder Supplier; (ii) is a supplier with an exemption under the Act; (iii) is a Second Tier Supplier and who was admitted as a Party in the capacity of a Supplier; or (iv) in accordance with Clause 6.8 has changed capacity such that it participates as a Party in the capacity of a Supplier ;
"Supplier Agent"	means any Meter Operator, Data Collector, Data Aggregator or Radio Teleswitch Service Access Provider appointed by a Supplier pursuant to Clause 39.1;
"System Data Provision Service"	means the system data provision service to be provided pursuant to Clause 21 (Registration Services, System Data Provision Service and Grid Control Centres);
"Transfer Standard"	means AC/DC Transfer Standard and AC Transfer Standard;
"Transmission System"	means the system for the transmission of electricity as defined in the Transmission Licences of ScottishPower Transmission Undertaking, Scottish and Southern Energy Transmission Undertaking, NGC or, in the case

	of NIE, the Transmission Licence granted to NIE pursuant to the Electricity (Northern Ireland) Order 1992;
"UTC"	means Co-ordinated Universal Time;
"Working Day" or "Business Day"	has the meaning given to that term in Section 64 of the Act when used in relation to England and Wales;
"Working Standard"	means a standard, including a complete Meter testing system, which has been verified by comparison to either a Reference Standard or a Transfer Standard, and is used for the calibration and testing of Metering Equipment;

Superseded